



# PRESS BRAKES

SMART, GENIUS, GENIUS-E,  
GENIUS-H, GIANT SERIES

[www.PRESSBRAKE.com](http://www.PRESSBRAKE.com)





Some of the Revolution Machine Tools Team

## ABOUT REVOLUTION MACHINE TOOLS

Revolution Machine Tools (RMT), founded by long time industry leader Kyle Jorgenson, is a metal fabrication machine tools company. RMT's design team has created the most innovative and precise tools in the North American market today. We are partners with leading manufacturers who build our designs to our stringent specifications in state of the art manufacturing facilities.

Kyle Jorgenson started in the Machine Tool industry working with his father, Roger Jorgenson, who founded Jorgenson Machine Tools in 1974. Roger taught Kyle how important relationships and customer service are, and Kyle has built his reputation on those principles. Revolution Machine Tools is supported by an ever expanding team of industry professionals, which include design, marketing, service and support, who have these same values and respect Kyle's vision. Together, they are creating a revolution in the Machine Tool industry.

RMT's main focus is in large cutting, forming, and rolling machines for the metal fabrication industry. RMT's research and development team has created the most innovative, fast, durable and accurate machines in the industry. Our machines are all backed by a strong warranty and an outstanding service team dedicated to keeping your machines operational. We understand the time value of money and how expensive downtime can be.





## **KYLE JORGENSON / President**

RMT offers several innovative machines including Fiber Lasers, Press Brakes, Plate Rolls, Ironworkers, Angle Rolls, Shears, Structural Steel Drills, Band Saws, Hydraulic Presses, Pipe Threading and Beveling, and much more. All RMT product designs are built for durability, precision, repeatability, and speed.

## **PRE-SALE CONSULTATION**

RMT's commitment to service begins with our site assessment consultation. Before we even discuss purchasing equipment we make an assessment of your production area to determine whether the equipment will work well in your manufacturing environment. We look at where the equipment will be placed on the production floor, how it will be brought into the facility, and even ways to make the disposal of scrap and waste easier to remove. We will also recommend the proper installation of our equipment, or we can even come install it for you. More importantly, we can verify adequate electrical, pneumatic or hydraulic requirements and we look at the surrounding equipment to assess if there are any electro-magnetic or vibration interference issues.





# REVOLUTIONARY SERVICE



## QUALIFIED SERVICE TECHNICIANS

Join the Revolution with service technicians from Revolution Machine Tools that can maintain, troubleshoot and fix your machines. Our goal at RMT is to ensure our customers experience smooth operations and greater return on investment by having their machines repaired and maintained by qualified personnel who are committed to the customer's success.

The service team at Revolution Machine Tools is experienced and able to diagnose, repair and install your equipment when you need it. We know that you can't wait for days or weeks to keep your production deadlines, and we are committed to minimizing your downtime and keeping your manufacturing processes moving forward.

## PREVENTATIVE MAINTENANCE PROGRAM

Keeping your machines operating at their peak performance is key to successful manufacturing. At Revolution Machine Tools, we have the right preventative maintenance plan to fit your needs; thus, keeping your machines performing at their most efficient levels.



Our service technicians will create the perfect preventative maintenance plan for you. They will evaluate your machines and provide you with a customized maintenance plan. Each plan will include general maintenance, safety evaluations, suggested repairs and part replacement.

## SERVICE WHEN YOU NEED IT

You can count on Revolution Machine Tools to be there when you need them. How many times have you needed customer service for a machine breakdown? Each and every breakdown equates to a loss in opportunity cost and profit. At Revolution Machine Tools, we are committed to making sure you get the most out of your equipment, and when it does breakdown, providing repair services in a timely manner.

So, if you are in need of a troubleshooting or repair, you can reach a service technician by phone or email and we will strive to respond quickly. You don't need help in two days, you need it now. You can count on Revolution Machine Tools because we are committed to getting you up and running when and where you need us.



# PARTS & TOOLING



## SUPERIOR PARTS AND TOOLING

Every machine used in the chipping, fabrication and forming of metal has consumables and tooling to keep them performing efficiently. These consumables and tools range from hydraulic oil, laser nozzle tips, replacement parts, software and more. Making sure you have the right products to take care of your machines is what we at Revolution Machine Tools specialize in. We stock the highest grade consumables, replacement parts and tooling to fit your needs; and, if on the rare occasion we don't have the part, we most likely know where to find it.

Our parts and tooling department is constantly looking for ways to maximize the potential of your machines. Specialized tooling can be ordered and shipped to your location. We have qualified customer service representatives who can help you find solutions and answers to your manufacturing needs.

Revolution Machine Tools and its staff are committed to providing you the most effective service possible. We encourage you to call, even if we don't carry your brand of machine, and see if we can support you in making sure you have the right parts and tooling to fulfill your production goals and needs.

## REPLACEMENT PARTS AND ACCESSORIES



RETROFIT SAFETY LASER SYSTEMS



ALL TYPES OF PRESS BRAKE TOOLING



HYDRAULIC PARTS



# BENEFIT OF RMT PRESS BRAKES

+ INDUSTRY 4.0

What better benefit can a machine provide than adding to your bottom line. RMT press brakes do this by helping you produce higher quality parts faster than ever and all with lower operating and maintenance costs. RMT has a press brake to match your needs and budget whether your application requires bending complex parts or simple shapes. RMT press brakes have been designed to be precise, reliable, and high performing with easy operation. We have a solution for every manufacturing environment and offer several models of press brakes with multiple features and options. Each of our press brake models have a variety of lengths and tonnages and can be customized to your requirements.

All RMT press brakes have been designed for high performance and are enhanced with five main innovations to increase your productivity while decreasing your cost per part including:

- 1) A rigid mono-block frame constructed from mill certified high-yield steel for dependable performance.
- 2) Quality precision ram positioning accurate to within 0.0004 inch provided by dual cylinders and rams for stable ram motion
- 3) A deeper throat allows you to use the full length of the machine to form more parts.
- 4) The increased daylight opening accommodates a larger range of tooling to allow forming of almost any part.
- 5) More stroke length which provides additional flexibility and versatility.

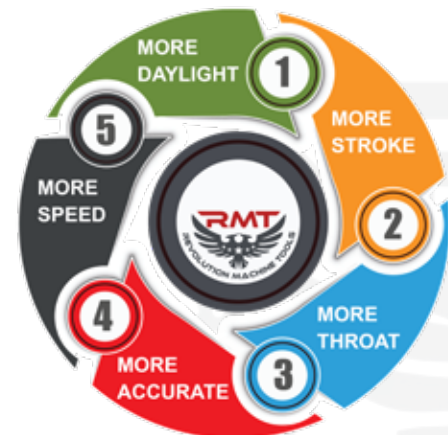

**We have many solutions available, or we can configure a machine to perfectly match your needs.**

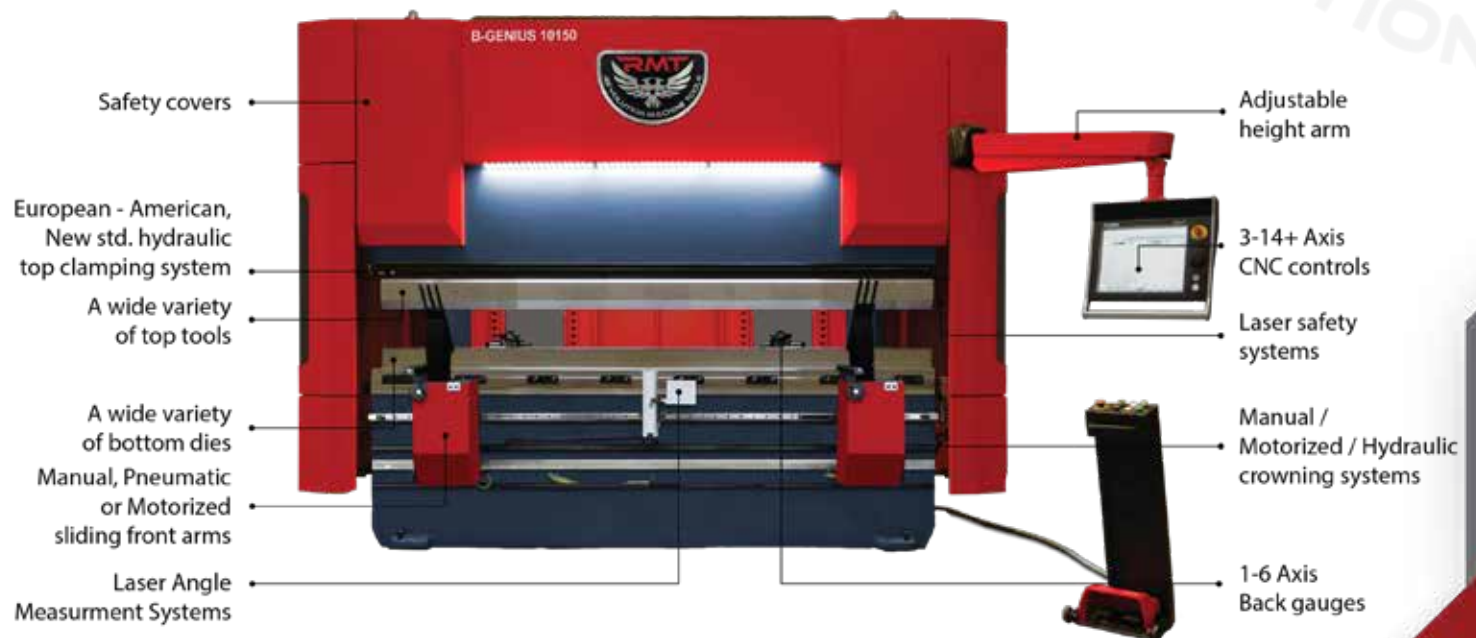

# PRESS BRAKE SERIES



## B-SMART SERIES

Standard 3 Axis CNC (Y1,Y2,X) up to 5 Axis  
6' - 20' Bending Lengths / 70-660 Tons  
Tandem / Trio / Quad Applications  
(for example, 2 x 20' = 40' bending capability)  
Flush Floor Press Brakes to 20' x 660 Ton

The B-SMART Series press brakes have larger daylight, throat depth and stroke for more cost effective production and versatility.

See pages 42-45



## B-GENIUS SERIES

Standard 7 Axis CNC Available 16+ Axis  
6' - 20' Bending Lengths / 70-660 Tons  
Tandem / Trio / Quad Applications  
Flush Floor Press Brakes to 20' x 660 Ton

The B-GENIUS Series press brake features an automatic CNC crowning system for improved part quality, a servo driven back gauge system for increased speeds, and a 3D capable graphical control unit to simulate bending sequences and collision points.

See pages 46-53



## B-GIANT SERIES

Standard 7 Axis CNC Available 14+ Axis  
14' - 20' Bending Lengths / 660 - 4000 Tons  
Single / Tandem / Trio / Quad Applications

RMT provides the latest technology in "large format" bending and automation for your big application press brake requirements. The B-GIANT Series combines high tonnage press brakes with automated material handling, providing a turnkey solution.

See pages 54-57





# PRESS BRAKE FEATURES

Features		B-SMART	B-GENIUS	B-GENIUS-E	B-GENIUS-H	B-GIANT
Tonnage Range		70-550	70-550	44-110	121-275	660-4000+
Bending Length Range		6' - 20'	6' - 20'	6' - 20'	6' - 20'	14' - 40'
Custom Lengths and Tonnages		O	O	O	O	O
Recommended Air Bending Sheet Metal Thickness Range		24 Ga - 5/8"	24 Ga - 5/8"	24 Ga - 5/8"	24 Ga - 5/8"	20 Ga - 4"
Obtainable Production Tolerances	Medium					
	Fine					
Part Geometries (without experienced operator)	Simple					
	Moderate					
	Complex					
Production Speed	Medium					
	High					
Controls	Tandem-Trio-Quad Configurations	O	O	O	O	O
	DELEM DA-53T	S	N/A	N/A	N/A	N/A
	DELEM DA-58T Graphical	O	N/A	N/A	N/A	N/A
	DELEM DA-66T Graphical Touchscreen	N/A	S	S	S	S
	DELEM DA-69T 3D Graphical Touchscreen	N/A	O	O	O	O
	Cybelec CNC Controls	O	O	O	O	O
Off-line Software	Adjustable Height Suspension Control Unit Arm	S	S	S	S	N/A
	Profile W Off-Line Software for DA-58T	O	N/A	N/A	N/A	N/A
	Profile T Off-Line Software for Delem 66T 69T	N/A	O	O	O	O
Part Measurement Systems	Radbend Off-Line Software	N/A	O	O	O	O
	Angle Measurement	N/A	O	O	O	O
Laser Bend Line	Part-Material Thickness Detection	N/A	O	O	O	O
	Laser Bend Line	O	O	O	O	O
Additional Foot Pedals	Additional Foot Pedals	O	O	O	O	O
Horn	29" + Horn left or Right Side	O	O	O	O	O
Throat Depth	Optional Additional Throat Height and Depth to 60"	O	O	O	O	O
Open Height	Additional Open Height above Standard Height	O	O	O	O	O
Stroke	Additional Stroke Length above Standard Length	O	O	O	O	O
Robotic Systems	Robotic Prep - Systems	N/A	O	O	O	O
Special Color	Custom Color	O	O	O	O	O
Air Conditioning	Air Conditioning for Electrical Panel	O	O	O	O	O
Back Gauge	1 Axis Back Gauge X Axis	S	N/A	N/A	N/A	N/A
	2 Axis Back Gauge X,R Axis	O	N/A	N/A	N/A	N/A
	4 Axis Back Gauge X,R,Z1,Z2 Axis	N/A	S	N/A	N/A	N/A
	5 Axis Back Gauge X,R,Z1,Z2 + X Prime +/- 5" Axis	N/A	O	O	O	O
	6 Axis Back Gauge X1,X2,R1,R2,Z1,Z2, Axis	N/A	O	O	O	O
	Custom Back Gauge Fingers	O	O	S	S	S
	Back Gauge Support Systems (For Material-Parts)	O	O	O	O	O
	Increased X Axis Back Gauge Travel to 40" + with Safety Light Barrier	O	O	O	O	O
	Double Guide Rail Back Gauge System	S	S	S	S	S
	Increased Back Gauge Travel-To Customers Requirement	O	O	O	O	O
Crowning	Manual Crowning	S	N/A	N/A	N/A	N/A
	CNC Controlled Motorized Crowning	O	S	N/A	S	N/A
	CNC Controlled Hydromechanical Crowning	N/A	N/A	N/A	N/A	S
Safety Systems	Laser Safety System	O	O	O	O	O
	MANUAL F. AKAS II M	S	S	S	S	S
	MOTORIZED F. AKAS III M	N/A	O	O	O	O
	SICK C4000 Light Curtain Systems	O	O	O	O	O

S = Standard / O = Option / N/A = Not Applicable

Hydraulic oil included in machines up to 250 Ton





Features		B-SMART	B-GENIUS	B-GENIUS-E	B-GENIUS-H	B-GIANT
Sheet Followers	Sheet Follower with Sliding Guide- With Motorized Height Adj. 275 lbs Each	N/A	0	0	0	N/A
	Sheet Follower with Sliding Guide- With Motorized Height Adj. 550 lbs Each	N/A	0	0	0	0
	Hydraulic Heavy Duty Type Front Arms	N/A	0	0	0	0
	Parking Station for Front Support Arms or Sheet Followers	N/A	0	0	0	0
Front Support Arms	Front Support Arms	N/A	N/A	N/A	N/A	N/A
	Multiple Sliding Front Arms with T-Slot, Tilting Stop and Full Length Linear Guide	S	S	S	S	S
Feeding Systems	F1-F2 Front Feeding System with Supports	N/A	0	0	0	0
	F1-F2 Front Feeding System with Supports + System for Light Poles	N/A	0	0	0	0
	X1 -X2 Axes with 50" + Travel (Light Pole)	N/A	0	0	0	0
Loading Systems	Feeding Automation - Conveyor Systems- Cranes- Loaders	N/A	0	0	0	0
Extraction Systems	Part Removal- Extraction Systems	N/A	0	0	0	0
Top Tools	RMT Common Precision Ground, 3.78" Tall Full Length Segmented American Goose Neck Punch	S	S	S	S	N/A
	Common Precision European Style Punch (Option- No Charge, if Traded for American Punch) (up to 440 Ton)	0	0	0	0	N/A
	Top "Punch" Tooling Common- Special Application - Infinite Possibilities (up to 440 Ton)	0	0	0	0	0
Top Tool Clamping Wila, Roller, Wilson	Section Clamps with Localized Height Adj. Max Load 30 Tons per Foot (up to 250 Ton)	S	S	S	S	N/A
	Section Clamps with Localized Height Adj. Max Load 53 Tons per Foot (350+ Ton)	S	S	N/A	S	S
	Manual Quick Release Section Clamps	0	0	0	0	0
	Manual-Mechanical Wila Top - NSCL-I-MC/UPB - PRO Max Load 60 Tons per Foot	0	0	0	0	0
	Hydraulic Wila Top - NSCL-I-HC/UPB - PRO Max Load 60 Tons per Foot	0	0	0	0	0
	Hydraulic Wila Top - NSCL-II-HC/UPB - PREMIUM Max Load 84 Tons per Foot	0	0	0	0	0
	RMT Top Clamping - Max Load 120 Tons per Foot	N/A	0	0	0	0
	RMT Top Clamping - Hydraulic - Roller Type- Max Load 134 + Tons per Foot	N/A	0	0	0	0
Wila HYD Standard "HD" Heavy Duty Clamping Max Load-Head load 84, Shoulder Load 269 Tons per Foot	N/A	0	0	0	0	
Bed Cap	Change from Standard Bed Cap- Wider or Narrower	0	0	0	0	0
	RMT 4 Way Die (2.36" Square) with 4V Die 85° with 5/8", 7/8", 1-3/8", 2" Openings	S	S	S	S	0
Bottom Tools	Full Length Multi V Die Block with Hardened Radius Shoulders	0	0	0	0	0
	Manual Adjustable V Die with Opening from 1.18" to 14" -with Roller Radius Shoulders	N/A	0	0	0	0
	CNC Adjustable V Die with Opening from 1.18" to 14" - with Roller Radius Shoulders	N/A	0	0	0	0
	Bottom Tools Common Stock - to Special Application (Infinite Possibilities)	0	0	0	0	0
Die Block-Holder	RMT Universal Die Block/Rail Flat Bottom, Accepts 2.36" (60mm) Square 4 Way, + has Slot for American or New Standard Single V Dies	S	S	S	S	N/A
	Full Length European Style U Type Flat bottom Die Block 60mm (2.36" wide opening)	0	0	0	0	N/A
	Full Length Die Block, from Common Stock to Custom's (Infinite Possibilities)	0	0	0	0	0
Bottom Tool Clamp Systems	Wila Manual MC Bottom - NSCR-I-MC-CNC/UPB - PRO- Max load 67 Tons per Foot	0	0	0	0	N/A
	Wila Hydraulic MC Bottom - NSCR-I-HC-CNC/UPB - PRO- Max load 67 Tons per Foot	0	0	0	0	N/A
	Wila Hydraulic Bottom - NSCR-II-HC-CNC/UPB-PREMIUM - Max load 100 Tons per Foot	N/A	0	0	0	0/N/A
	Wila Hydraulic Bottom -Clamp- HD Pro-Max Load 168 Tons Per Foot - HD Premium 269 Tons Per Foot	N/A	0	0	0	0
Tool Positioning Systems Wila, Roller, Wilson	Pneumatic Bottom Tool Positioning Systems	N/A	0	0	0	0
	Hydraulic Bottom Tool Positioning - Separation Systems	N/A	0	0	0	0
Powerpack for Hyd. Clamping	Powerpack for all Hyd. Clamping	0	0	0	0	0

Due to ongoing product development, machine specifications can change at any time.

**Pressbrake Bending Tonnage Chart** (tons per ft. of bend @ specific die opening / radius)

THICKNESS	WIDTH OF LOWER DIE OPENING																											
	Gauge	1/4	5/16	3/8	7/16	1/2	5/8	3/4	7/8	1	1-1/8	1-1/4	1-1/2	2	2-1/2	3	3-1/2	4	5	6	7	8	10					
20	.036	3.1	2.3	1.8	1.4	1.2	1.0																					
18	.048	5.4	4.0	3.1	2.5	2.2	1.7	1.3																				
16	.060	9.6	7.1	5.6	4.5	3.8	2.8	2.2	1.8	1.5																		
14	.075		11.9	9.3	7.6	6.4	4.7	3.8	3.0	2.5	2.1	1.9																
13	.090						6.8	5.5	4.3	3.7	3.3	2.9																
12	.105				20.5	16.7	13.5	10.4	7.7	6.5	5.6	4.4	4.1	3.2	2.2													
11	.120						18.5	13.9	10.9	8.8	7.5	6.2	5.6	4.3	3.2	2.2												
10	.135						25.2	17.2	14.5	11.3	9.9	8.5	7.3	5.7	4.0	2.9	2.3											
9	.150									13.1	11.9	9.0	7.0	5.2	3.7													
3/16	.188									27.4	23.1	19.3	16.4	14.3	11.2	7.6	5.8	4.5										
1/4	.250											39.4	33.3	29.5	22.7	15.4	11.5	9.1	7.5	6.2								
5/16	.313													50.4	39.8	27.0	19.7	16.0	12.7	10.6	7.7							
3/8	.375															61.1	42.3	30.9	24.0	19.6	16.3	12.3	9.5					
7/16	.437																	61.7	45.8	35.4	28.6	24.4	17.3	14.8	11.2			
1/2	.500																		85.2	63.6	48.8	39.7	33.3	24.6	19.4	15.9	13.1	
5/8	.625																			110.0	86.2	70.0	58.3	43.1	33.3	27.4	23.3	16.9
3/4	.750																				110.0	93.0	69.0	53.5	43.6	36.5	27.1	
7/8	.875																					137.0	104.0	80.7	64.6	52.9	39.7	
1	1.000																						143.0	113.0	91.2	76.2	56.3	
Formed Radius		1/32	3/64	1/16	5/64	5/64	3/32	1/8	9/64	5/32	11/64	3/16	15/64	5/16	25/64	15/32	25/64	5/8	25/32	15/16	1-3/32	1-1/4	1-9/16					
Min. Flange Dim.		3/16	7/32	1/4	9/32	5/16	7/16	1/2	5/16	5/8	11/16	3/4	15/64	1-3/16	1-7/16	1-3/4	2	2-1/4	2-3/4	3-3/8	4	4-1/2	5-1/2					

www.RMTUS.com



# MAIN FEATURES

## RIGID FRAME CONSTRUCTION & DUAL HYDRAULIC CYLINDERS

The foundation of all RMT press brakes is a solid, mono-block frame made from mill certified, high-yield steel. As a result, RMT press brakes perform accurately and reliably year after year. We're so confident in our construction, we offer a 10-year frame warranty with our standard machines.

Dual hydraulic cylinders located on either side of the ram provide faster approach speeds. The cylinders are synchronized to provide smooth motion resulting in precise ram positions to accuracies of .0004"

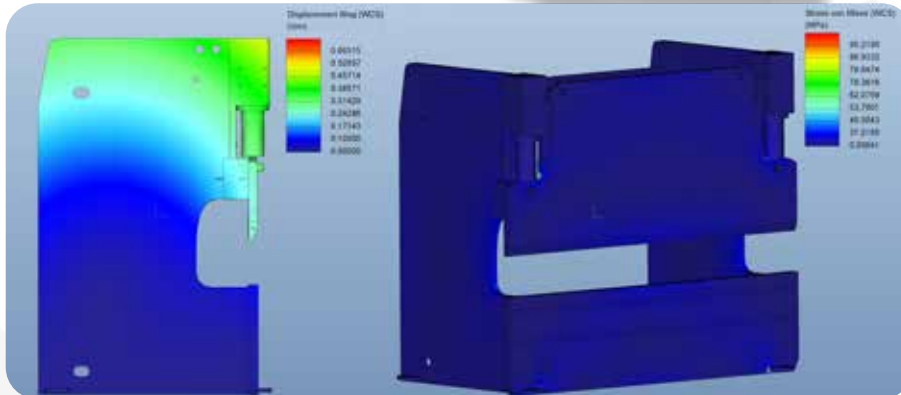
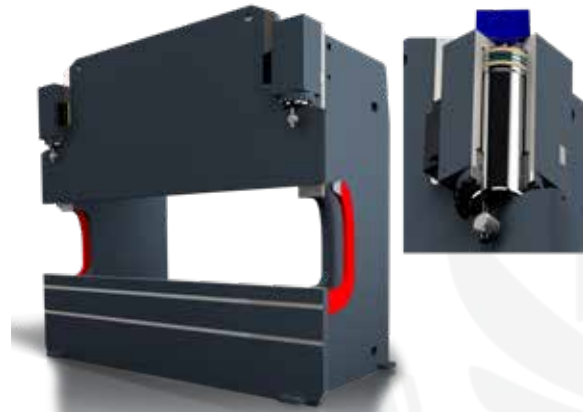

## KEYED AND INTERLOCKED CONSTRUCTION

Standard on B-GIANT and Optional on B-GENIUS, B-GENIUS E and B-GENIUS H



## WIDE FRAME DISTANCE

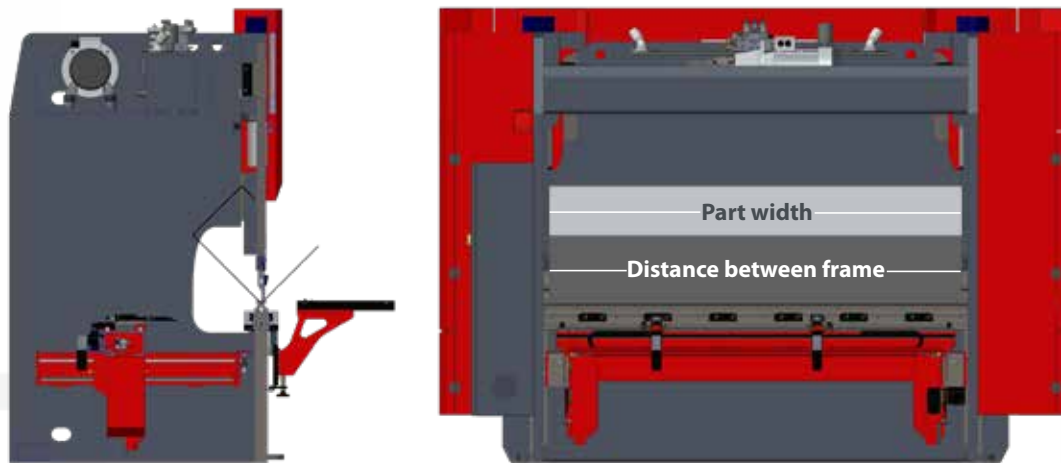

RMT press brakes can easily accommodate parts with deep bends and that require long tooling because of our open space design. Our machines typically have deeper throat depths, larger daylight spaces and longer stroke lengths than any manufacturer in the market.

We've also mounted the RAM GUIDING on the outside of the frame to maximize the distance between the side frames so our press brakes can accommodate deep part flanges.

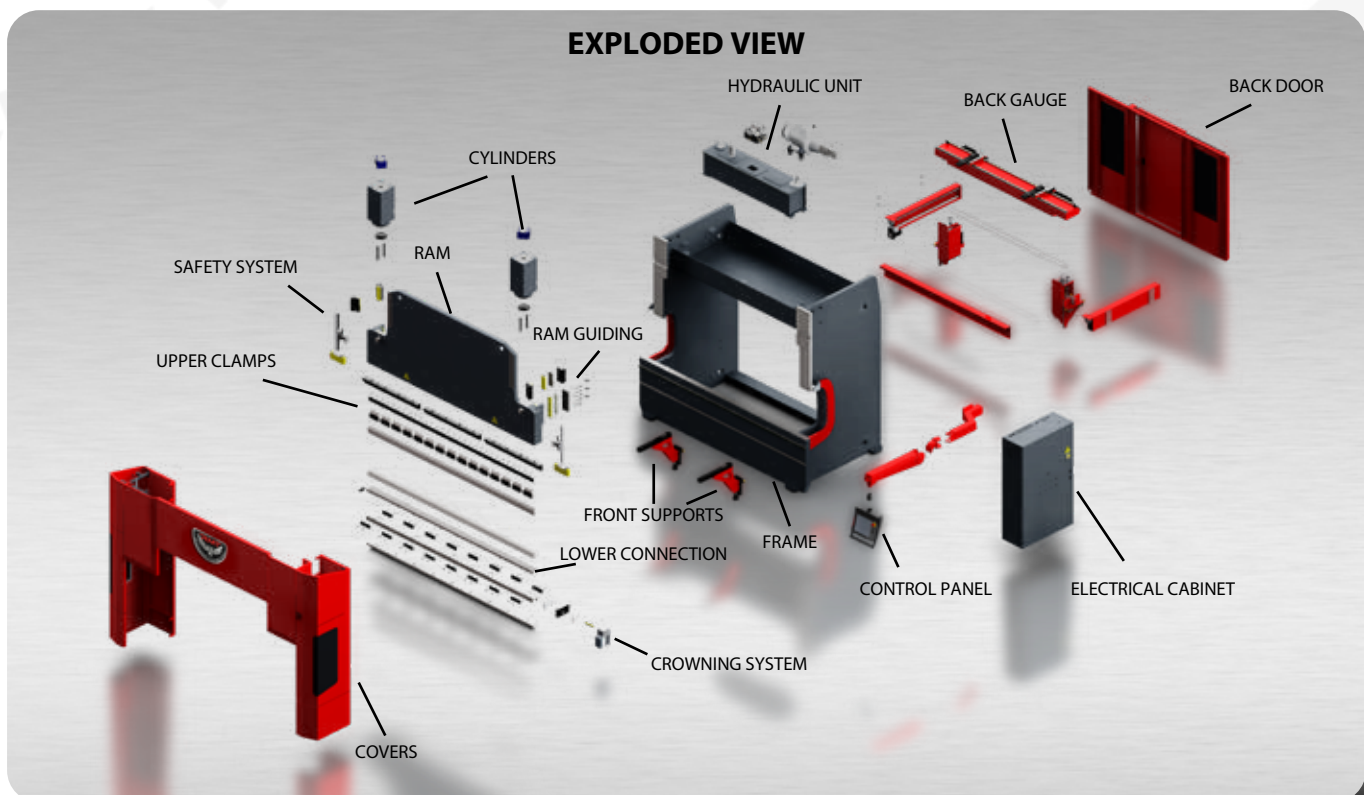



# STANDARD FEATURES

## ENLARGED WORKING SPACE

The RMT press brake has large open height, large ram stroke, and large throat depth to assist with the production of large parts and provides clearance when bending parts with large flanges.



## HYDRAULIC SYSTEM

Hydraulic proportional direction and pressure control valves (Hoerbiger, Germany) determine the position of the ram. Safety valves protect against overloads and high pressure and can warn the operator or even stop the machine.



## RAM GUIDING & POSITIONING

The ram is guided by four slideways. There are two inner slideways located above the ram and two outer slideways located at the bottom. The ram is also tiltable for conic bending applications. Slide location allows for easy adjustment and maintenance. The high precision linear encoders control the position of the ram, with .0001 precision.



## Y1-Y2 RAM POSITIONING SYSTEM

The ram positioning system consists of independently controlled cylinders and linear encoders which are attached on each side of the sub frame and automatically compensates for any yaw. The servo hydraulic valves, the CNC command center and the linear encoders provide accessibility to program the position, speed, and tilt as well as superior accuracy. The programmability of this system along with custom decompression point and programmable speed is very helpful when bending large sheets.

# SAFETY SYSTEMS



## MANUAL F. AKAS II M

Standard on all models

Point of operation safety is the responsibility of the owner and operators. RMT machines can be equipped with ram-mounted AKAS-LC Safety Light Guards which are located at the bend level and centered around the location of the punch tip. The laser system is fixed to the ram and follows the ram or punch tip allowing for a continuous safety light grid allowing for maximum safety without interfering with workflow.



## MOTORIZED F. AKAS III M

Optional

An AKAS motorized receiver-transmitter adjustment system can be installed on your machine which is adjustable to set the height of the receiver and transmitter to allow for punch changes and will automatically reset after different punch dimensions are installed.

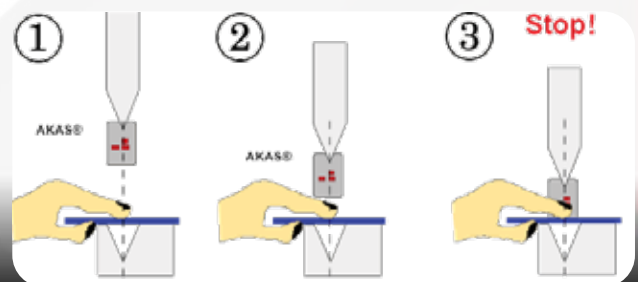



# CONTROL SYSTEMS

## DELEM DA-53T

Standard CNC Control B-SMART Series

The compact DA-53T is a complete CNC solution for Y1-Y2 synchronized press brakes. The touch screen panel based control, capable of controlling up to 4 Axes, can be integrated in cabinets as well as in an optional pendant arm housing.

Equipped with the Delem user-friendly interface, the DA-53T provides all main press brake functionality. The unique 'hotkey' navigation gives direct access to the programs in memory and enables quick and easy programming of a product.

All common bend parameters are located on one page. For advanced parameters an additional page can be selected. Angle programming of the Y-Axis, crowning function and pressure control are standard on board. USB interfacing enables the use of memory sticks as a fast product and tool backup medium.



### Features of the Delem DA-53T Control Unit

- Quick, one page programming
- Hotkey navigation
- 10.1" high resolution color TFT
- Up to 4 Axes (Y1, Y2, and 2 auxiliary axes)
- Crowning control
- Tool/material/product library
- USB memory stick interfacing
- Advanced Y-Axis control algorithms for closed loop as well as open loop valves
- Panel based controller with optional housing

### Standard

- Synchronized / conventional press brake control
- Color LCD display
- 10.1" widescreen TFT
- LED back light
- Industrial grade touch screen
- Memory capacity 1 GB
- 266 MHz processor
- Tool library
- 30 punches
- 30 dies
- Data backup / restore via USB
- Power-down memorization
- Integrated valve amplifier

### Programming

- 7 digits program number
- 20 character drawing number
- Stock counter (up to 9999)
- Step repetition (up to 99)
- Millimeter / Inch
- One page programming table
- 'Teach-in' on all axes
- Radius programming (bumping)
- Programmable axis speed per step
- Programmable material properties
- 30 punches

### Computed

- Tooling safety zones
- Press force
- Bend allowance
- Crowning adjustment
- Bottoming force
- Angle correction database



## DELEM DA-58T

Optional CNC Control B-SMART Series

The DA-58T provides easy CNC programming with the Delem 2D graphical product design tool. Machine adjustment and test bends are reduced to a minimum because of the quick and easy to use bend sequence determination tool.

The CNC program is generated with a one touch key stroke. You are ready to make the first part since all axes positions are automatically computed and the bend sequence has already been simulated on the screen with the machine and tools in real scale. In the production mode of the DA- 58T the operator can graphically simulate the bend process of the product guiding him during the press brake operation.

The basic machine control functions are Y1-Y2 and X Axis. A second back gauge axis can be used as R/Z or X2 Axis. Also the crowning function is standard.



### Features of the Delem DA-58T Control Unit



- 2D graphical programming
- 15" LCD TFT color display
- Bend sequence determination
- Developed length calculation
- Crowning control
- USB peripheral interfacing
- Servo, frequency inverter and AC control
- Advanced Y-Axis control algorithms for closed-loop as well as open-loop valves.

#### Standard

- Synchronized / conventional press brake control
- Color LCD display
- LED back light
- 15" LCD TFT color display, 1024 x 768 pixels
- 500 MHz processor
- Industrial grade touch screen
- Memory capacity 1 GB
- Tool library
- 30 punches
- 60 dies
- Data backup / restore via USB
- Power-down memorization
- Integrated valve amplifier

#### Programming

- 7 digit program number
- 20 character drawing number
- Stock counter (up to 9999)
- Step repetition (up to 99)
- Millimeter / Inch
- Programmable axis speed per step
- Programmable material properties
- 2D product programming and visualization
- Graphical bend sequence determination
- Fast collision check
- Free programmable tools
- Graphical tool programming
- Radius programming (bumping)

#### Computed

- Tooling safety zones
- Press force
- Bend allowance
- Crowning adjustment
- Bottoming force
- Angle correction database
- Developed length
- Auto bumping calculation





## DELEM DA-66T / 69T

DA-66T - Standard control on B-GENIUS, B-GENIUS-E, B-GENIUS-H, and B-GIANT Series

DA-69T - Optional control on B-GENIUS, B-GENIUS-E, B-GENIUS-H, and B-GIANT Series

The new generation DA-Touch controls offer an even higher grade of efficiency in programming, operation and control of today's press brakes. Ease of use combined with state-of-the-art technology go hand in hand, improving productivity. The touch screen gives access to the proven Delem user-interface and enables direct navigation between programming and production. Functions are directly located where you need them, offering optimized ergonomics throughout the application.

The DA-66T offers 2D programming that includes automatic bend sequence calculation and collision detection. Full 3D machine set-up with multiple tool stations giving true feedback on the product feasibility and handling.

The DA-69T offers 2D as well as 3D programming that includes automatic bend sequence calculation and collision detection. Full 3D machine set-up with multiple tool stations giving true feedback on the product feasibility and handling.

Highly effective control algorithms optimize the machine cycle and minimize set-up time. This makes using press brakes easier, more efficient and more versatile than ever.

The OEM-panel located above the screen, reserved for machine functions and OEM application switches, is integrated in the design and can be used depending on the required application.



DELEM DA-66T

## Features of the Delem DA-66T / 69T Control Unit

- 2D graphical touch screen programming mode
- 3D and 2D graphical touch screen programming mode (DELEM DA-69T)
- 3D visualization in simulation and production
- 17" high resolution color TFT
- Full Windows application suite
- Delem Modusys compatibility (module scalability and adaptivity)
- USB, peripheral interfacing
- Open system architecture
- Sensor bending & correction interface

### Standard

- Color LCD display
- 17" TFT, high brightness
- 1280 x 1024 pixels, 32 bit color
- Full touch screen control (IR-touch)
- Storage capacity 1 GB
- Storage capacity 2 GB (DELEM DA-69T)
- 3D graphics acceleration
- Standard Windows® networking
- Emergency switch
- Integrated OEM-panel
- USB flash memory drive

### Field option

- Part support control
- X1-X2 angle programming
- Bar code reader interfacing
- Protractor interfacing
- Frame deflection compensation
- Sensor bending & correction interfacing
- Sheet thickness measurement and compensation system



DELEM DA-69T



### General

- Real-time embedded Windows® OS
- Multitasking environment
- Instant Shut Off
- Delem Modusys compatible

### Electrical / interfacing

- Power supply: 24V
- Modusys HSB bus
- RS232 port (2x)
- Network interface (100Mb/10Mb)
- USB port (2x)
- SafetyPLC interfacing
- Protractor interfacing
- Angle control interfacing

### Control

- Servo- / 2 speed AC control
- Unipolar / frequency inverter control
- Direct pressure valve control
- Direct proportional valve Y1, Y2 control
- Direct crowning control
- Multiple digital function outputs
- Tandem operation

### Programming

- Alphanumeric product naming
- Real-scale product programming and visualization
- 2D/3D real-scale product programming and visualization (DELEM DA-69T)
- Automatic bend sequence calculation
- Automatic bend sequence calculation in 2D and 3D (DELEM DA-69T)
- Easy graphical bend sequence swap and move
- Hemmed products programming
- One page programming table
- Graphical product and tool selection
- Programmable material properties
- Programmable axis speed
- Free material programming
- Product & tool search filter
- Millimeters/Inches, kN/Ton selection
- Stock counter
- Product notes

### Tooling

- Graphical tool configuration
- Multiple tool station set-ups
- Tool segmentation visualization
- Alphanumeric tool identification
- Free graphical tool programming
- Hemming tools
- Radius tools
- Tool adapter support



### Computed

- Tooling safety zones
- Press force
- Bend allowance
- Crowning adjustment
- Developed length
- Bottoming force
- Hemming force
- Auto bumping calculation
- Radius programming
- Bend allowance table
- Learned angle correction database

### Miscellaneous

- 'Teach-in' on all axes
- Hand wheel movement of all axes
- Operator selectable dialogue languages
- Integrated help functions
- Error messaging system
- Diagnostic program
- Internet Explorer (web browser)
- Remote diagnosis
- User specific applications support
- Machine time + stroke counter
- On board Analysis Tool
- Sequencer functionality (PLC)



# SOFTWARE

## RADAN RADBEND OFF-LINE SOFTWARE

OPTIONAL



Radbend from Radan is the comprehensive off-line programming solution for press brakes. Completely integrated with Radan3D it also provides a full 3D simulation of the bending process.

Features at a glance:

- User-defined bend allowances
- Flexible design changes including material thickness
- Automatic, associative drawing elevations
- Associative 2D dimensioning on drawing elevations and flat blanks
- An integrated component of Radan
- The software is specifically focused on the rapid creation and modification of 3D sheet metal parts and assemblies. The system understands the attributes of sheet metal and utilizes user-definable parameters for precise automatic unfolding.

Based on the ACIS solid modeling kernel and employing modern parametric techniques, it provides design flexibility, and a unique 2D-to-3D method of creating 3D objects.

In addition, Radan 3D allows the import of a range of file formats, including Inventor, Solidworks, Catia V4 & V5, SAT, IGES, STEP and Parasolid, as well as the creation of assemblies in the 3D environment.

The Radan 3D model can be updated with manufacturing information such as expected radius and setback values, from Radbend, Radan's off-line programming solution

With Radbend you will be able to select the most tools to bend the part correctly. The program will run a full 3D simulation of the bending process detecting any problems or potential collisions. The software will also automatically position finger stops against every valid face requiring fingerstops and provide you with feedback, on the expected radius, press depth, etc.

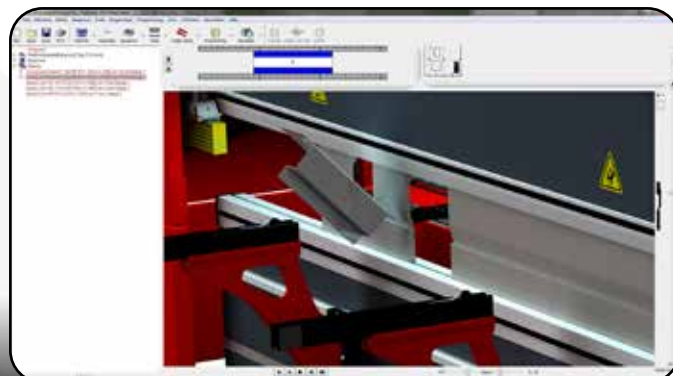
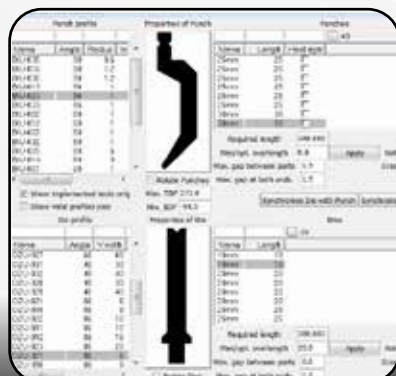
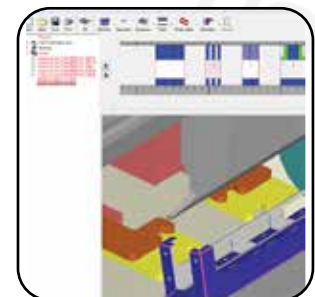
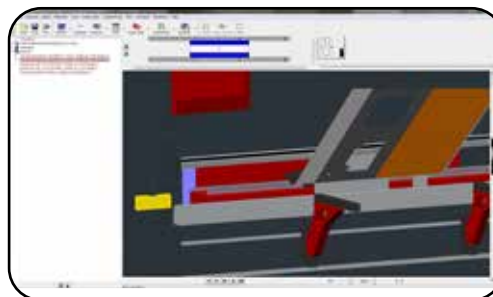
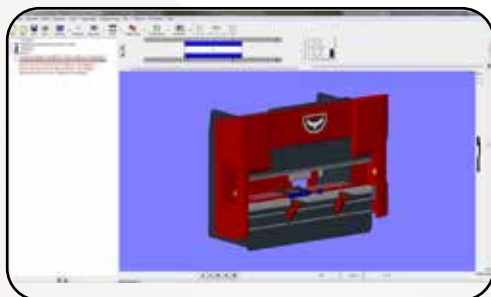

## DELEM PROFILE T OFF-LINE SOFTWARE

Standard on DA-66T and DA-69T

Maximize your machine efficiency and production output by taking your press brake programming off-line with Delem's most innovative software, Profile T.

Production preparation, make-ability and tooling verification, operator training, adding notes for production and many other functions can be carried out off-line using Profile T.

The Profile-T software offers advanced programming in 2D/3D in line with the DA-Touch controller software.

Programming the product graphically shows a true scale representation of the intended product. Realistic product visualization gives feedback on feasibility, collisions, required tools and tool adapters for production.

Profile T Features:

- Full scale off-line programming
- Graphical product programming and bend sequence generation
- Feasibility studies and production preparation
- 2D/3D automatic bend sequence calculation
- Collision detection
- Product sharing over Windows networking with press brake CNC
- Machine setup preparation including print functionality
- Production time calculation

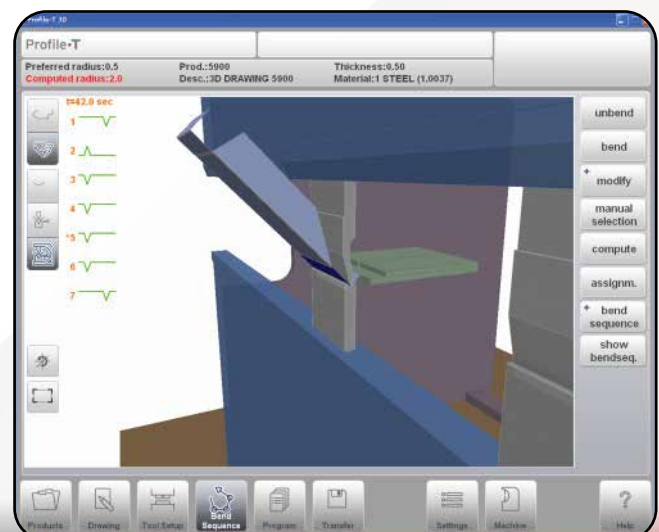
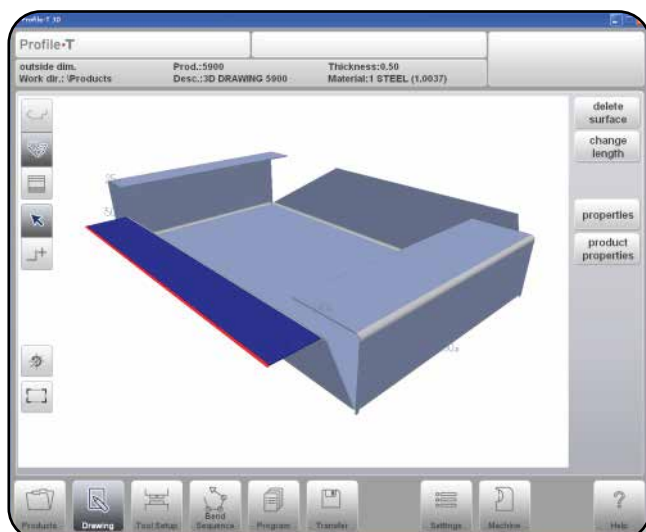



# CROWNING SYSTEMS

To confirm a constant bend angle, pre-load the machine with manual or CNC crowning which will offset potential deviations and allow for possible tooling wear to maintain parallel contacting surfaces. CNC crowning systems allow the press brake control to be pre-programmed with machine characteristics and deflection data. Manual crowning requires the simple development of a chart or spreadsheet for each new application. Varying properties in material can cause different outcomes and calculations/setting may need to be adjusted accordingly.

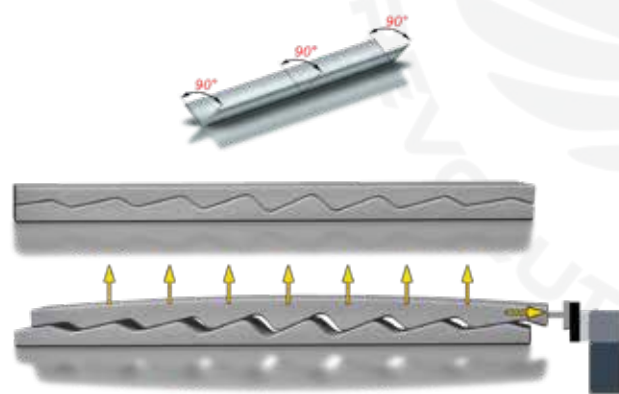
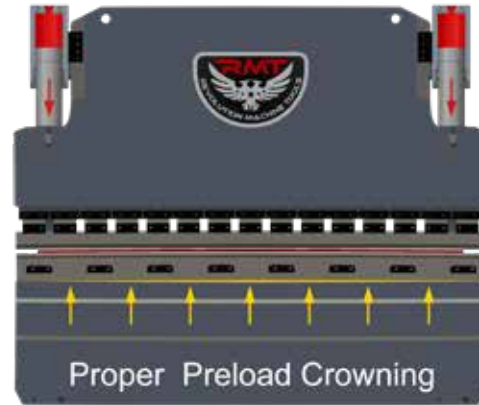
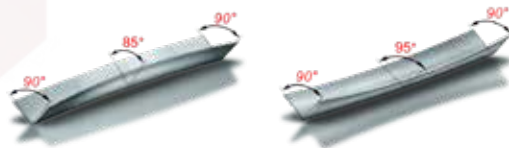
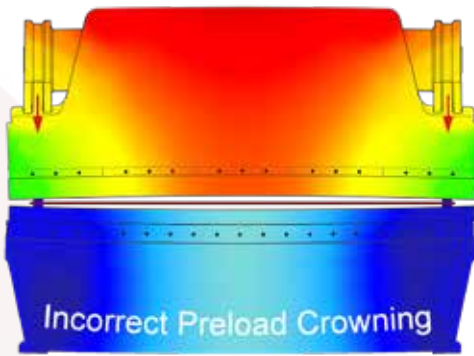

Exaggerated to Demonstrate

## MANUAL CROWNING

Standard on B-SMART



## CNC MOTORIZED CROWNING

Standard on B-GENIUS and B-GENIUS-H  
Optional on B-SMART



# SHEET SUPPORT SYSTEMS



## SLIDING FRONT ARMS

Standard on all models

The sliding front support arms are mounted with a ball bearing system and linear guides to allow for effortless lateral and quick and easy vertical adjustments.



## CNC SHEET FOLLOWERS

Optional on all models except B-SMART

This feature allows for quicker and safer part production through continuous synchronized support throughout the bending process and also helps prevent back bending.

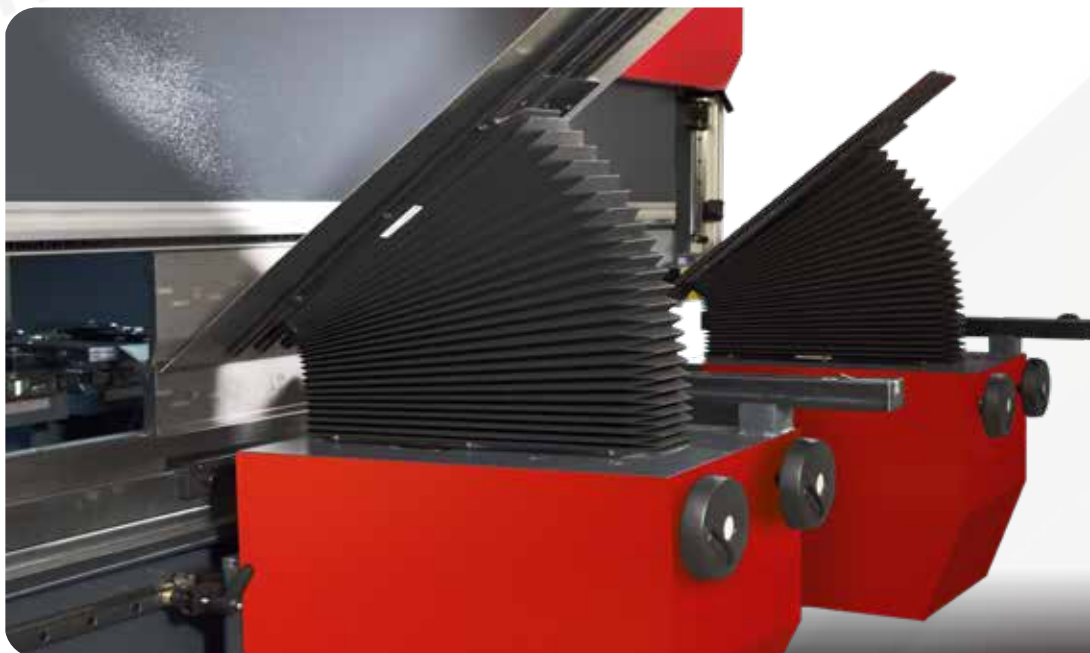



# BACK GAUGE SYSTEMS

Establishing the right back gauge for your projects will allow for increased part production and precision. From intricate parts which typically require more axes to large quantities that require more time and therefore increased cost, the correct back gauge for each job is essential to lowering costs per part which ultimately benefits your bottom line. RMT technicians are happy to assist you with any questions you may have on your project requirements.

### 1 Axis Back Gauge (X)

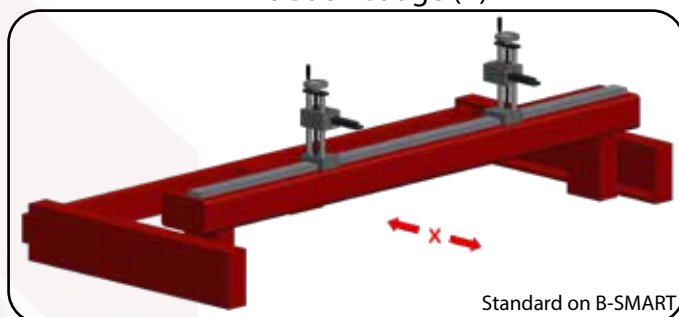

### 2 Axis Back Gauge (X,R)

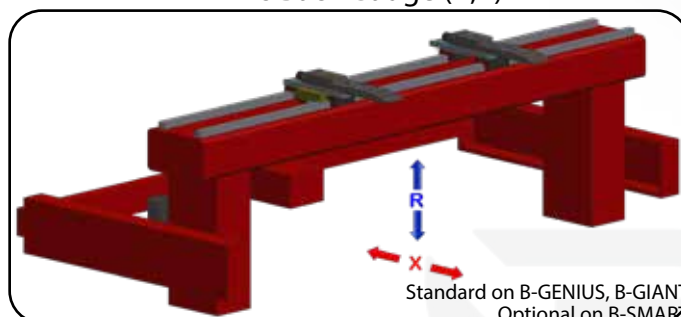

### 4 Axis Back Gauge (X,R,Z1,Z2)

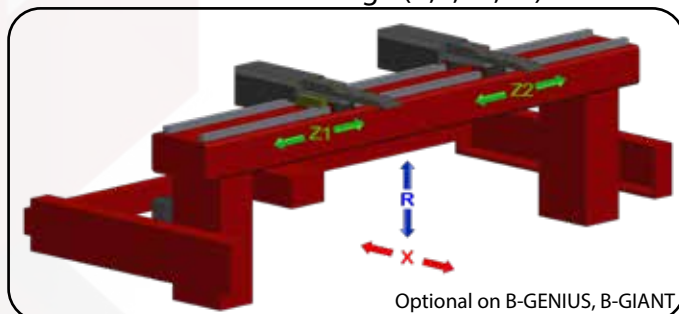

### 5 Axis Back Gauge (X,R,Z1,Z2, X Prime)

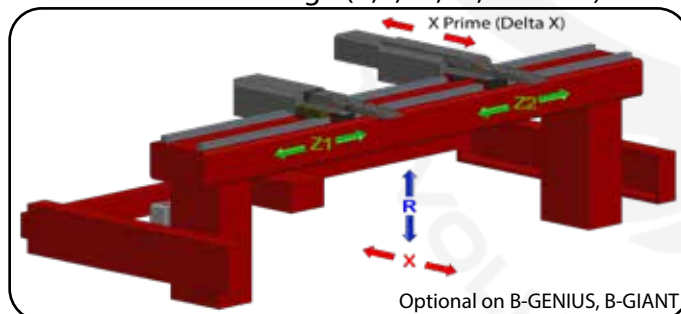

### 6 Axis Back Gauge (X1,X2,R1,R2,Z1,Z2)

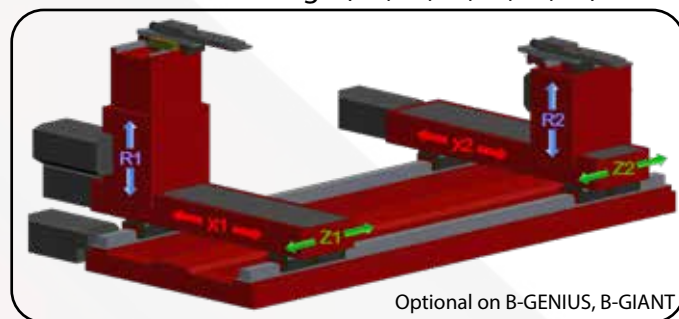

### 3 Step Fingers

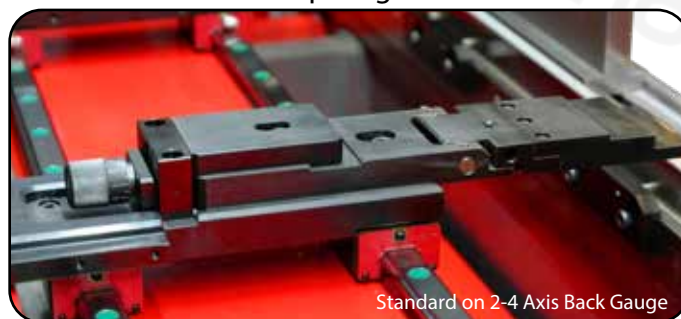

### Optional Back Gauge Support



### Optional Special Fingers



# 1 AXIS BACK GAUGE

Standard on B- SMART



The CNC 1 Axis back gauge is standard on all B-SMART press brakes. With a 1 Axis Back Gauge the X Axis is motorized and CNC controlled and the R Axis has manually adjustable height to control the finger block.

The finger depth (X Axis) is calculated by a motorized CNC controller and includes a retraction feature to eliminate collision incidents. The back gauge fingers are easily adjustable for calibration and can also be moved manually and fixed in place. The R1, R2, Z1, Z2 Axes can also be adjusted manually and secured in place.



## 2 AXIS BACK GAUGE

Optional on B-SMART



The CNC 2 Axis back gauge comes standard on the B-GENIUS line of press brakes and is an option that can be added to a B-SMART series press brake. The 2 Axis back gauge is CNC controlled to adjust the X (depth) and R (height) Axes to ensure your material is accurately positioned for a high quality finished product.

By using Mitsubishi servo motors and drives along with HIWIN ball screws or HIWIN or Rexroth linear rails, you can program X Axis speeds up to 1200 IPM with an accuracy of .0004".

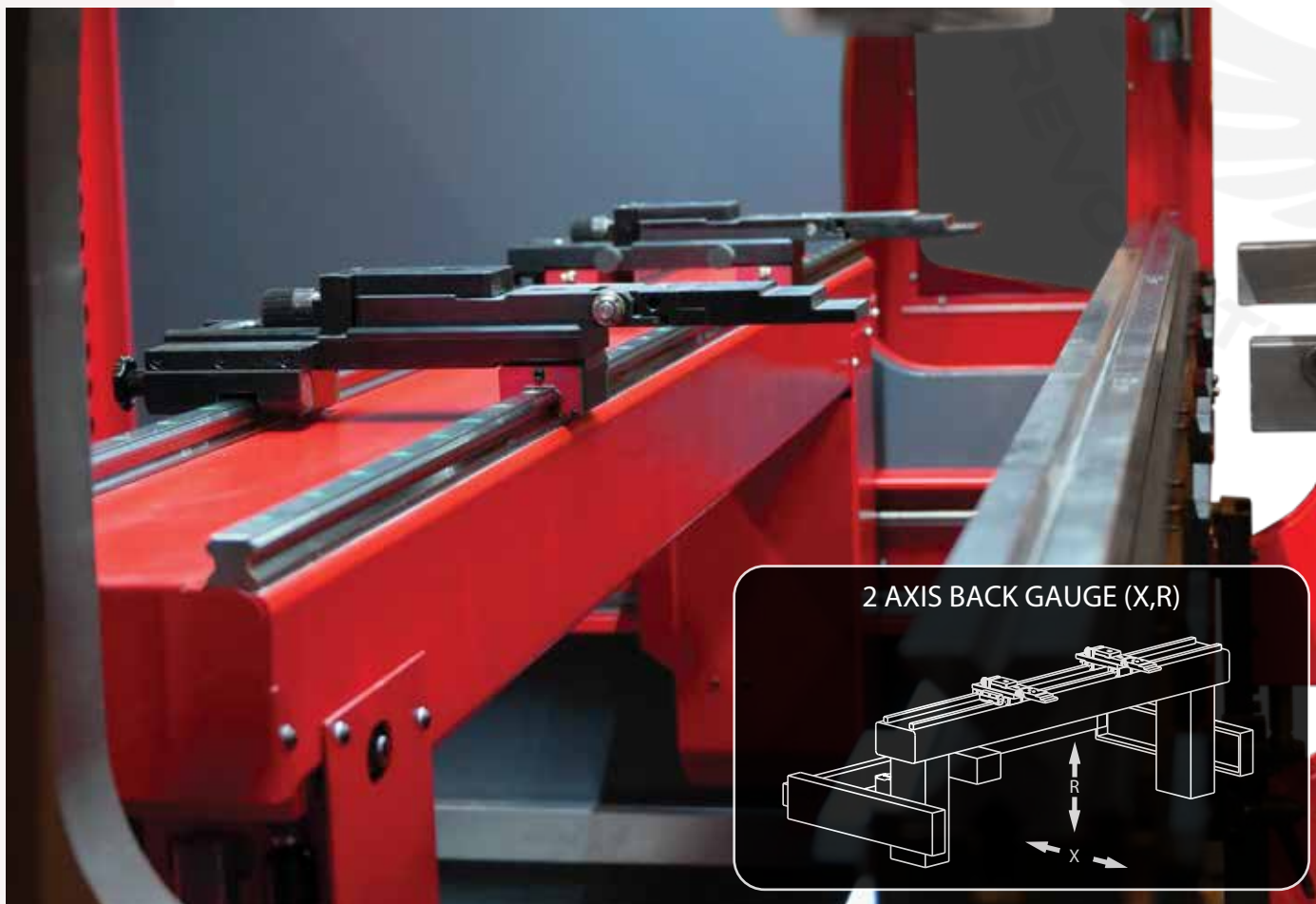





## 4 AXIS BACK GAUGE

Standard on B-GENIUS, B-GENIUS-E, B-GENIUS-H and B-GIANT

Our B-GENIUS press brakes are equipped with a fast and precise 2 Axis CNC controlled back gauge. 4 Axis CNC back gauge (X-R-Z1-Z2) is standard now. With this back gauge system the CNC press brake control calculates the depth, height and width of the back gauge fingers. This back gauge features superior accuracy and speed. This translates to more correct parts at the end of the day.

By using Mitsubishi servo motors and drives along with HIWIN ball screws or HIWIN or Rexroth linear rails, you can program X Axis speeds up to 1200 IPM with an accuracy of .0004".





## 5 AXIS BACK GAUGE

Optional on B-GENIUS, B-GENIUS E, B-GENIUS-H and B-GIANT



Need to bump your versatility up a notch? On top of X, R, and Z1, Z2 add X prime to the back gauge to allow independent shifting of a finger to assist in asymmetrical part creation. The finger can shift forward or backward 5" for a total travel of 10" which facilitates precision slant lines.

By using Mitsubishi servo motors and drives along with HIWIN ball screws or HIWIN or Rexroth linear rails, you can program X Axis speeds up to 1200 IPM with an accuracy of .0004".

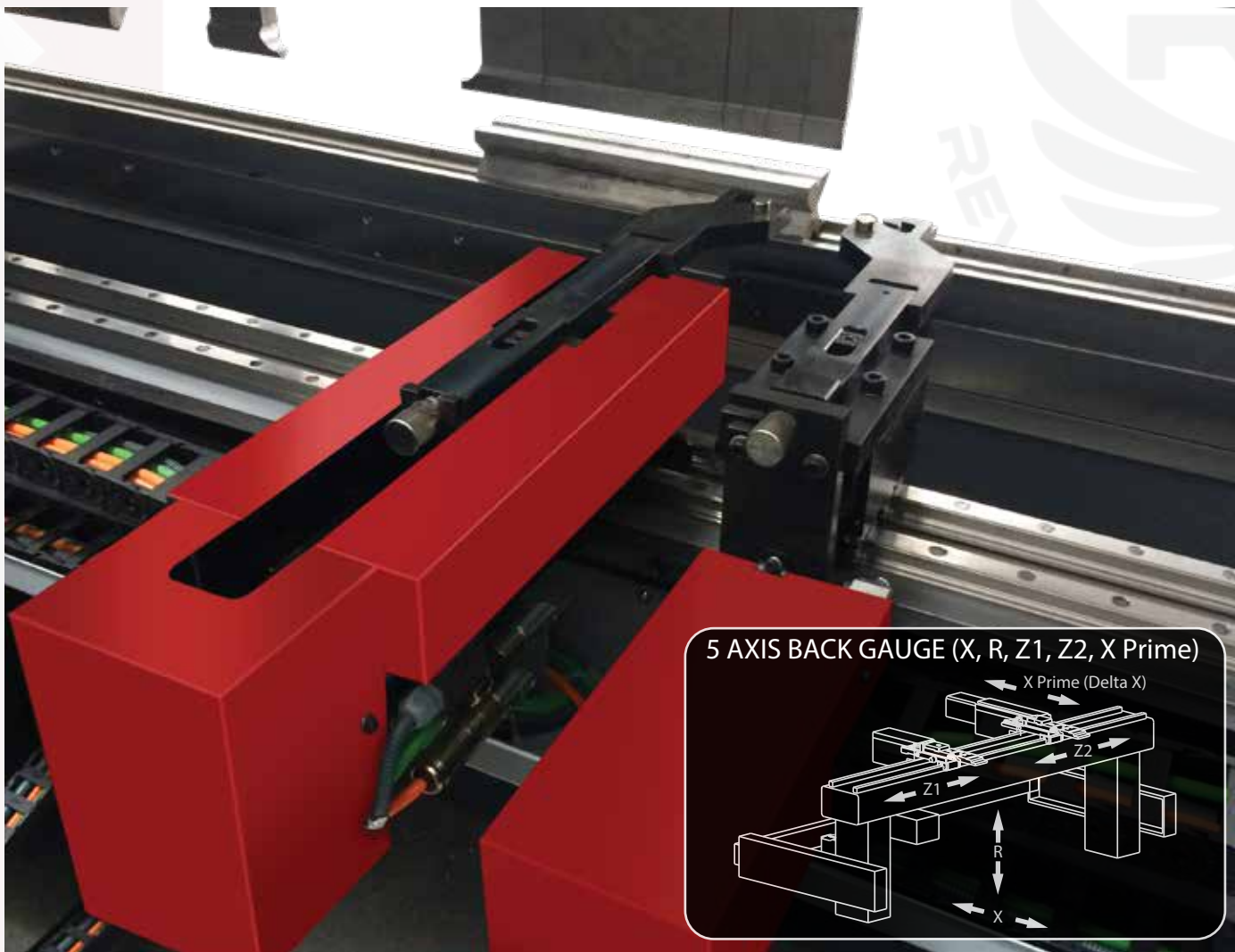

## 6 AXIS BACK GAUGE

Optional on B-GENIUS, B-GENIUS-E, B-GENIUS-H and B-GIANT

The 6 Axis back gauge allows for the most flexibility and quickest production speeds as all 6 Axis back gauges can be positioned independently of each other. The controller calculates the finger positions three dimensionally (X, R, Z) in the space. Steady finger positions, especially for asymmetrical parts, eliminate the need for back gauge adjustments and help you save setup time.

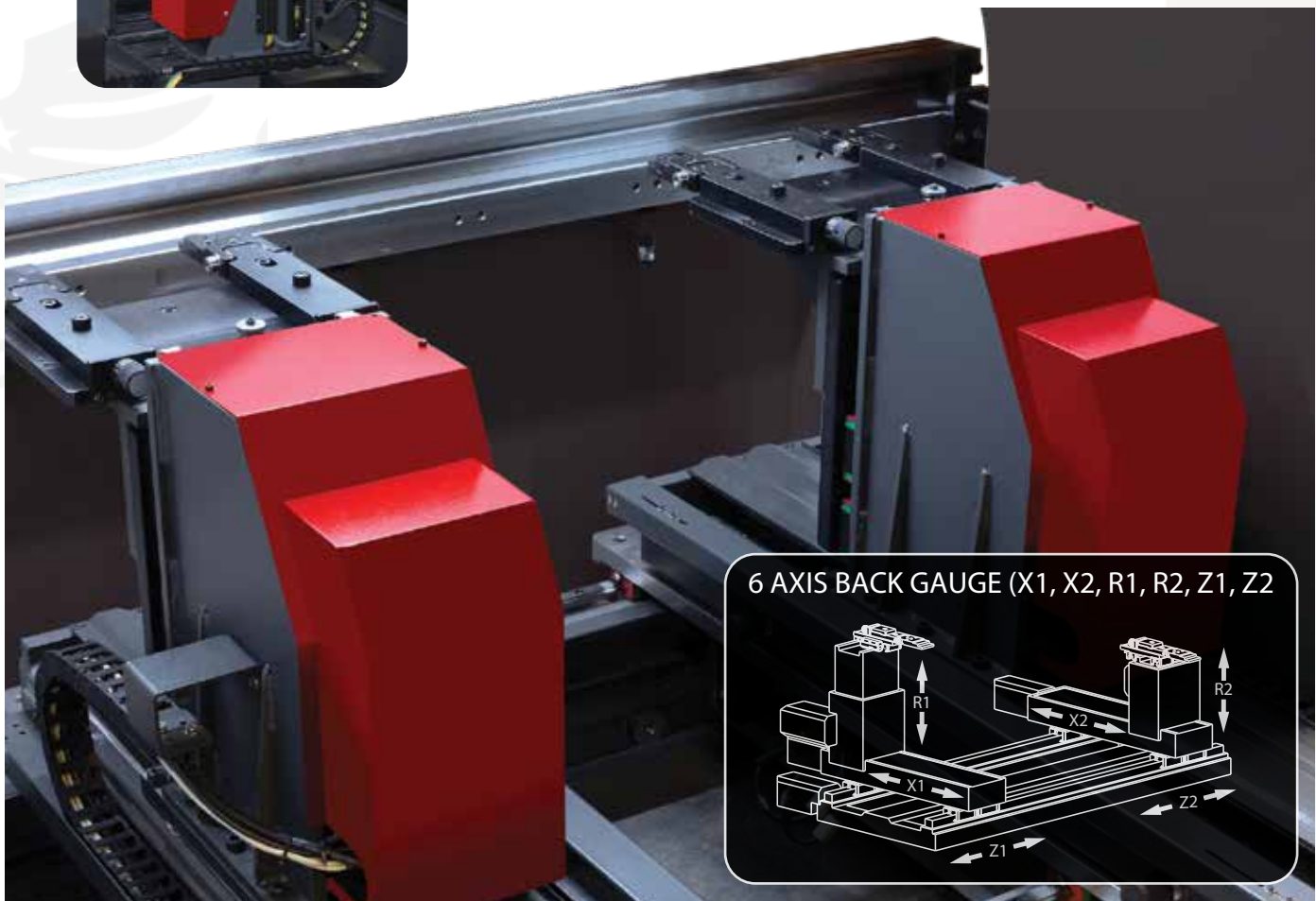
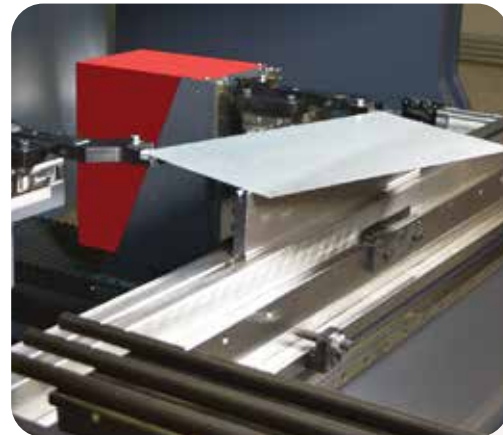

6 AXIS BACK GAUGE (X1, X2, R1, R2, Z1, Z2)

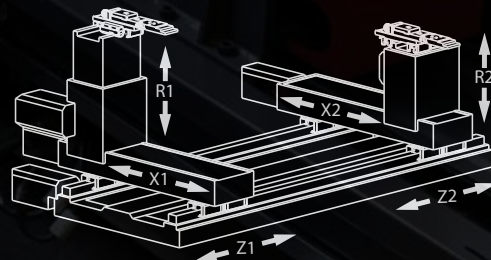



# TOOLING

RMT styles many tooling systems made for your business. RMT universal connection systems are easily adaptable to many styles of tooling. This means flexibility today and tomorrow with economic possibilities. To REALLY increase productivity, add a hydraulic clamping system (see pages 31-33).

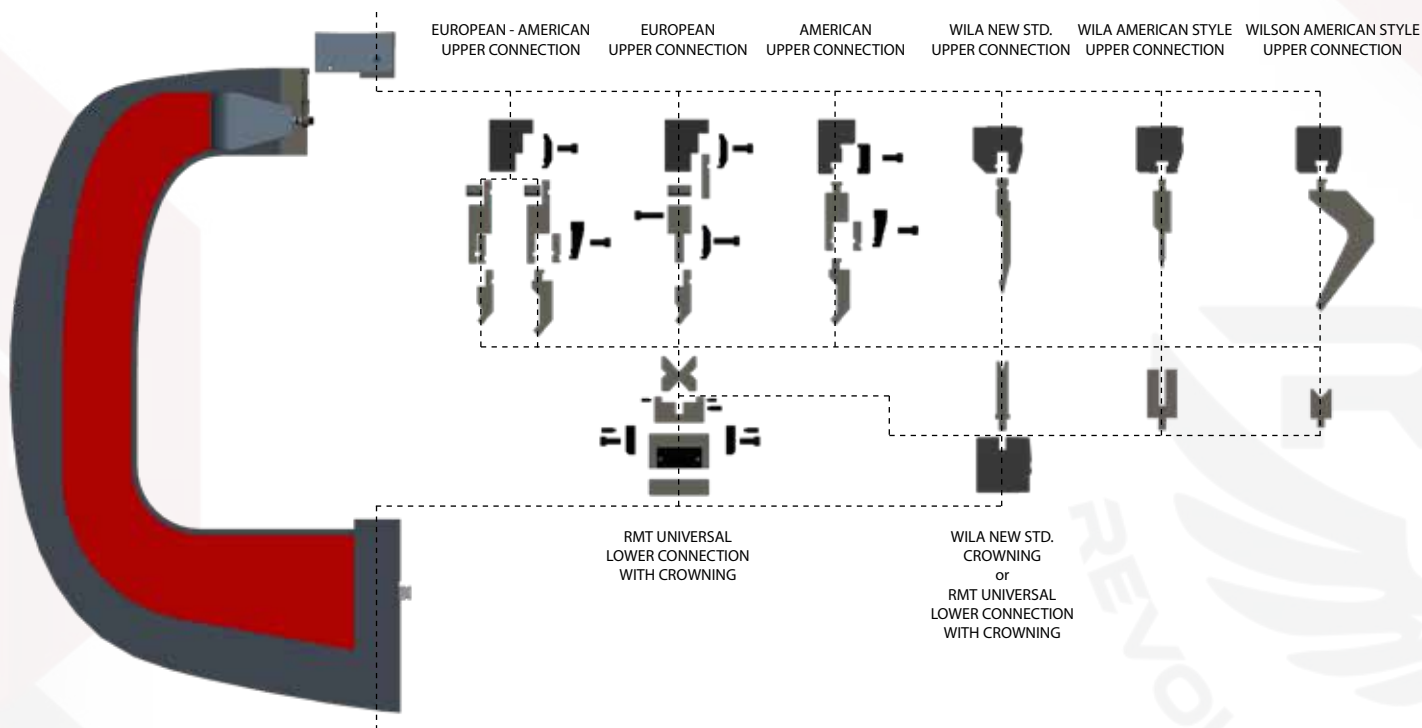

We can supply tooling for any application

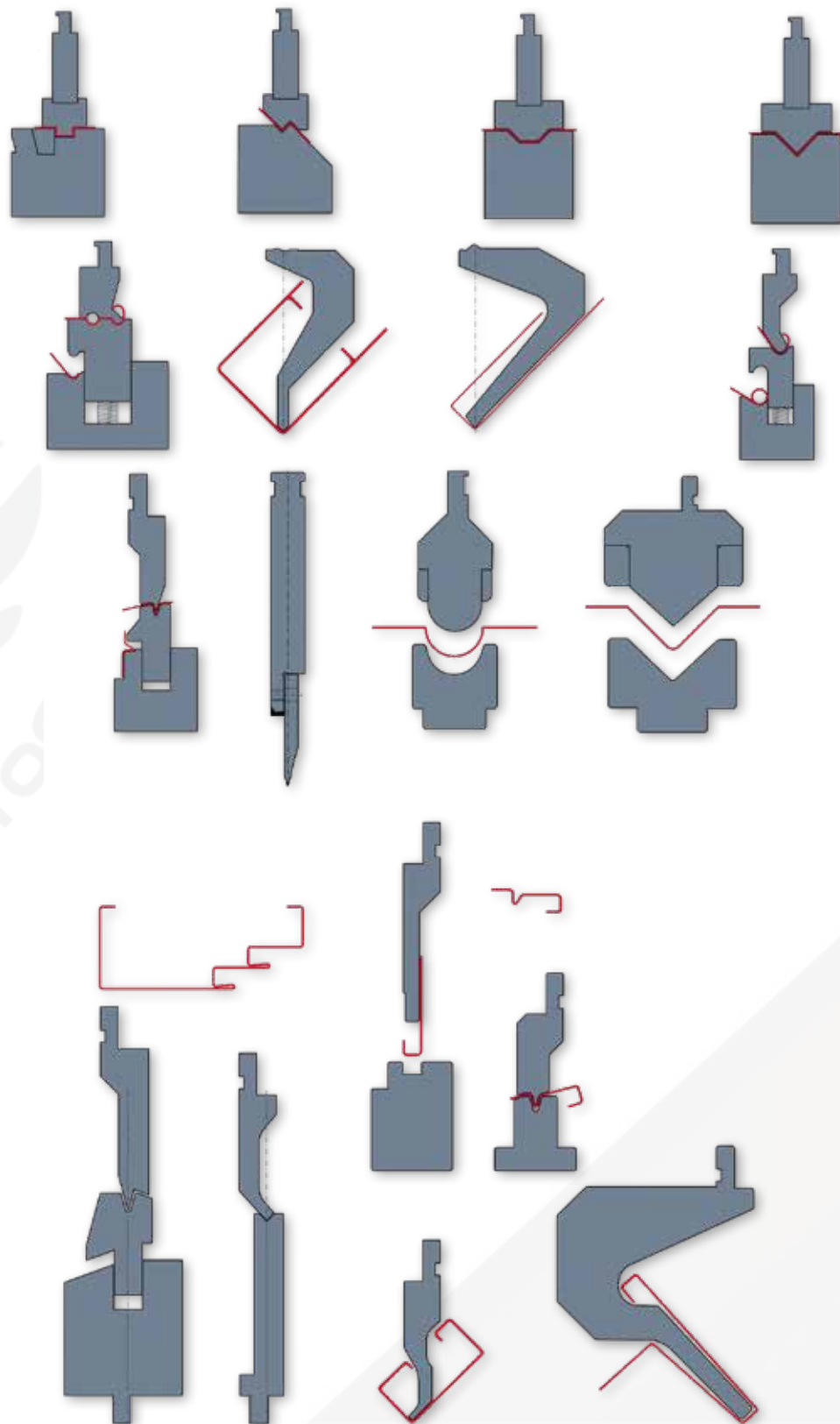



# STANDARD TOOLING

Standard on all models up to 440 ton

## EUROPEAN-AMERICAN DIE BLOCK

Standard Universal punch clamps accept European or American style punch tooling. Standard on all models up to 440 Tons



"U" type flat bottom with 2.36" (60mm) inside width, die block suitable for European Style dies. Standard with machine is also a 4 way V die with 5/8", 7/8", 1-3/8" and 2" 85 degree V die opening is standard equipment. Many other optional tooling systems are readily available.

## EUROPEAN-AMERICAN TOP CLAMPING



The tall section clamps are very useful in deep box forming. They are designed with an integrated wedge which allows vertical adjustment to offset any deflection or tool wear. 33 tons per foot section clamps. Standard on all models 250 Tons - 53 tons per foot.

# OPTIONAL TOOLING



## NEW STANDARD HEAVY DUTY HYDRAULIC TOP CLAMPING



Wila's hydraulic New Standard HD clamping has up to 268 Tons per foot max. load capacity.

## SPECIAL PUNCH ADAPTERS



Special punch adapters and radius inserts eliminates the need to change large and heavy tools, increasing flexibility and tool changeover times, and dramatically reducing long-term tool cost.

## SMART TOOL LOCATOR



The locator uses LED lights integrated in the clamping system to show the operator where to position the tooling. The lights are controlled by the press brake CNC. The locator also indicates to the operator where to make the next bend, following the bend sequence of the part that is being formed.

## ROLLER SLIDE TOP CLAMPING



Roller slide punch removal with integrated upper crowning dramatically reduces tool changeover times compared with conventional mechanical systems.



## NEW STANDARD HYDRAULIC TOP CLAMPING



Wila's hydraulic New Standard clamping is a state-of-the-art system that operates quickly and easily without any external moving parts. PRO up to 60 Tons/foot, PREMIUM up to 83 tons per foot

## HYDRAULIC DIE CLAMPING

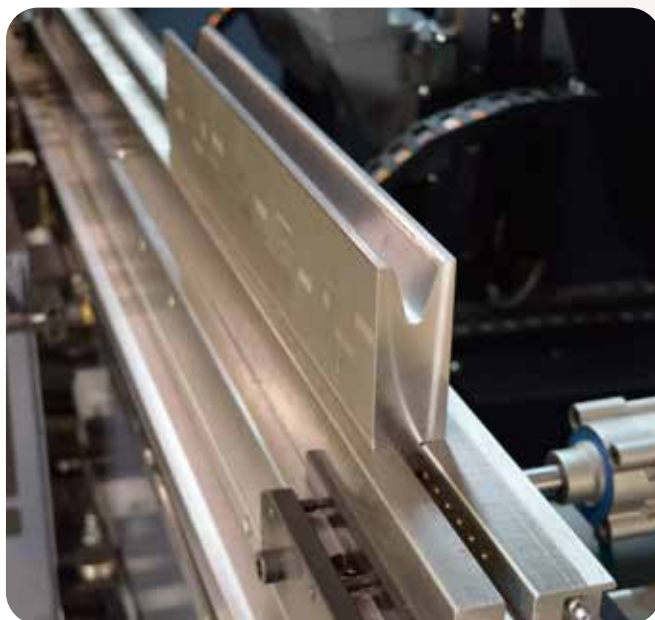

Hydraulic die clamping provides an equally fast method of securing the lower dies. It is available for both American/European and New Standard style dies.

## RMT HD TOP CLAMPING



Built to withstand loads up to 120 Tons per foot for demanding jobs with heavy load over a short area.

## RMT HD HYDRAULIC TOP CLAMPING



Built to withstand loads up to 340 Tons per foot for demanding jobs with heavy load over short area.

## MULTI V DIES WITH HARDENED RADIUS SHOULDER

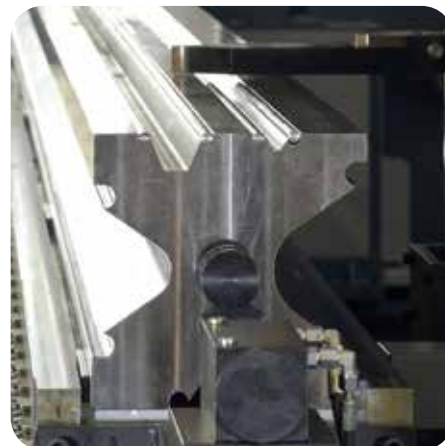

These inserts are hardened and placed in the shoulder area of the lower V die. This reduces friction as the punch pushes the material into the die.



## ADJUSTABLE DIES



Many dies in one versatile tool.

Suitable for applications that demand bending of different thickness and high tensile materials which normally require die changes. Adjustable dies allow you to quickly and easily bend material needing different radius bends. Also, the radius shoulder allows for decreased bending force and fewer to no witness marks on the material. This means better looking, higher quality parts, as well as longer tool life.

## ADJUSTABLE STEP DIES

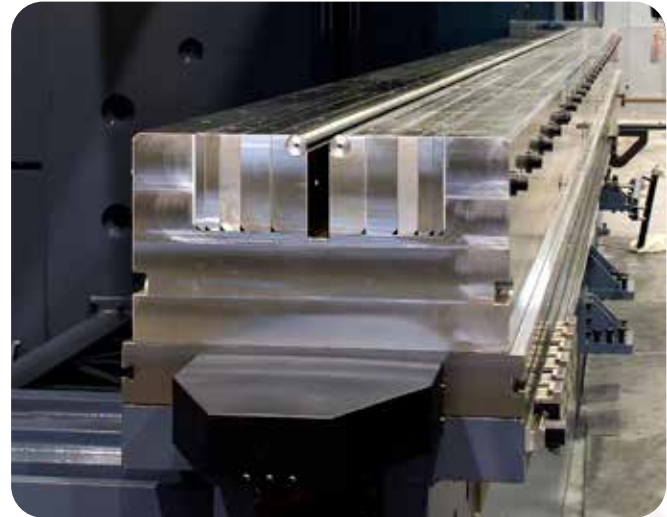

## PROGRAMMABLE DIES

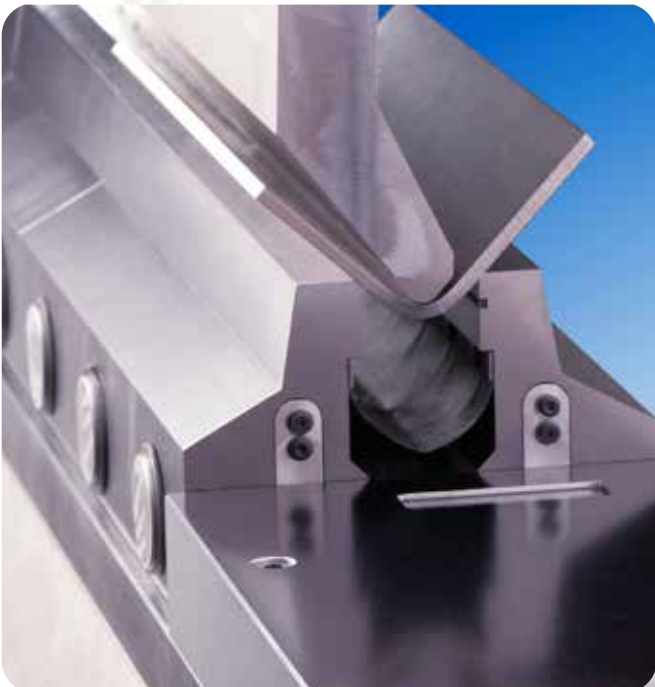

Programmable variable V dies can dramatically reduce bottom tool setup time while adding flexibility.

## CNC LARGE VARIABLE OPENING DIES





Achieve the highest level of productivity, Precision Tooling from Wila

## NEW STANDARD PRO TOOLS



## CUSTOM MADE TOOLS



## NEW STD. PREMIUM TOOLS



## AMERICAN STYLE TOOLS



### CUSTOM MADE RADIUS TOOLS

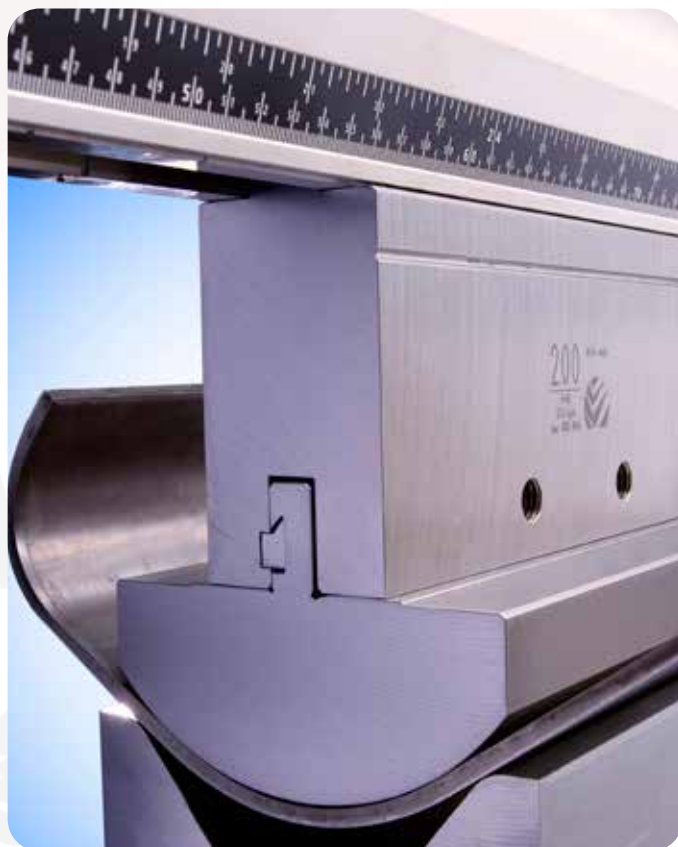

### ROAD BARRIER TOOLS



### CUSTOM SWAN NECK TOOLS



### CUSTOM MADE TOOLS RADIUS HOLDER WITH INSERT





# BOTTOM TOOL POSITIONING SYSTEM

Can be very useful for using two stage hemming dies or switching between V die openings

## PNEUMATIC POSITIONING

Optional on B-GENIUS, B-GENIUS-E, B-GENIUS-H and B-GIANT

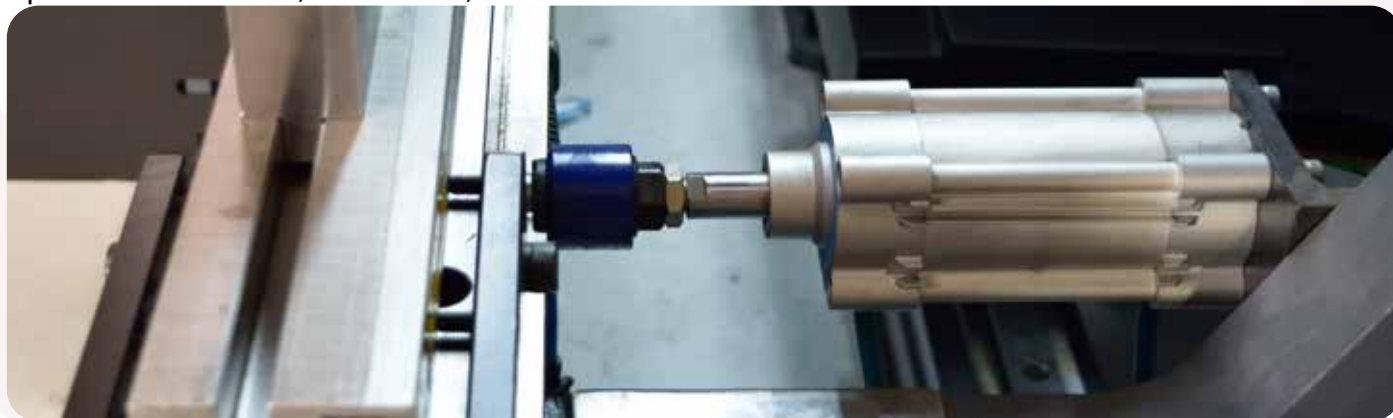

## MOTORIZED POSITIONING (I AXIS)

Optional on B-GENIUS, B-GENIUS-E, B-GENIUS-H and B-GIANT



## TOOL SEPARATION SYSTEM

Optional on B-GENIUS, B-GENIUS-E, B-GENIUS-H and B-GIANT



# LASER ANGLE MEASUREMENT SYSTEM

Optional on B-GENIUS, B-GENIUS-E, B-GENIUS-H and B-GIANT



## BEND ANGLE VARIABLES

### Tooling

- Tolerances of the tools:
  - Height of the die
  - Height of the punch - tip to shoulder
  - Angle on punch and die
  - Shoulder radius on die
- Seating and alignment
- Wear of punch and die

### Material

- Thickness variations
- Yield strength variations
- Grain considerations
- Protective coatings
- Spring back
- Type
- Hardness

Manufacturing sheet metal parts with accurate angles that are kept constant at all times, even when material parameters change, is very difficult. The best solution is a laser-based angle measuring device.

- Lasers can measure any bending angle.
- Lasers are very compact - everything is contained in the appliance.
- Lasers are accurate regardless of lighting influences. Working with light or dark material surfaces have almost no effect on a laser.



# WANT A WORKHORSE?

## 3 AXIS CNC SYNCRO PRESS BRAKE

The 3 Axis CNC Syncro Press Brake is our most popular model by volume and a true workhorse. Constructed of high quality parts and offering serious reliability, Y1 & Y2 technology with high approach, bending and return speeds.

- Provides a combination of performance, cost effectiveness and easy to use features
- Outstanding Value! Best brake for the money on the market.
- User friendly CNC control unit and software
- Precise bending results
- Tough construction with the same solid framework we use for all of our RMT Press Brakes
- Large daylight opening allows the entire length of the machine to be put to optimal use
- Designed and built with the objective to help you achieve low cost manufacturing
- Standard 3 Axis CNC X, Y1, Y2 and manually adjustable R1, R2, Z1, Z2

## B-SMART SERIES

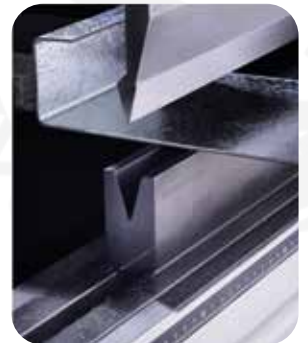

# B-SMART SERIES

## PRESS BRAKE

+ INDUSTRY 4.0



### STANDARD

- 3 Axis CNC:
  - Y1, Y2 precision ram positioning
  - X Axis Back Gauge
- Large trio of value:
  - Large open height
  - Large stroke
  - Large throat depth
- Back Gauge - motorized & linear guide & ball bearing system
- Back Gauge Fingers - height adjustable
- Safety laser with manual F. AKAS II M-FPSC-B-C + safety covers with switch
- Delem DA-53T CNC control unit
- Manual crowning
- Clamping:
  - American/European section-style box punch clamps
  - American-only style punch clamp available at no charge
- Quick-set sliding front sheet support arms with full-length linear guide, tilting stop and T-slot (front gauge squaring, etc.)
- Adjustable height suspension control unit arm
- Protective covers (side and rear safety doors)
- Rear work light
- World-class hydraulic and electronic components that are easily replaceable (parts stocked by us or available off-the-shelf from your local supplier):
  - Hydraulic blocks and valves (Hoerbiger)
  - Electronics system (Siemens, Schneider, Mitsubishi)
- High-yield plate construction
- Hydraulic Oil (up to 250 Ton machines)

### OPTIONAL

- CNC R Axis
- Delem DA-58T CNC control unit with 2D graphics, includes a seat of profile-T off-line software
- Safety laser with SICK C 4000 (only for tandem) + steel protective covers
- Adaptive bending sensors (angle measurement)
- Top tool American or European
- Bottom tool American or European
- Hydraulic tooling clamping systems
- Quick release clamping
- Universal die blocks
- CNC controlled motorized crowning
- Extended back gauge stroke & back protection with light barrier
- Oil coolant
- Very reasonable tooling packages available (multi-V tooling)
- Additional finger blocks
- Additional sliding front arms
- Tandem, Trio, Quad configuration



# B-SMART

B-SMART SERIES	STANDARD MACHINE CHARACTERISTICS											
	BENDING FORCE	BENDING LENGTH	DISTANCE BETWEEN FRAMES	RAM STROKE	DAYLIGHT	THROAT DEPTH	BED HEIGHT	BED CAP WIDTH (STANDARD)	BED CAP WIDTH (OPTIONAL)	# SLIDING FRONT SUPPORT ARMS	MOTOR POWER	OIL TANK CAPACITY
	(US)	A	B	C	D	E	F	G1	G2	QTY		
	Tons	Feet	Feet	Inch	Inch	Inch	Inch	Inch	Inch	Pcs.	HP	Gal
B-SMART 6-70	70	6' 10"	5' 7"	11"	20.9"	16.1"	35.4"	4"	7"	2	10	40
B-SMART 8-110	110	8' 6"	7' 3"	11"	20.9"	16.1"	35.4"	4"	7"	2	10	40
B-SMART 10-110	110	10' 2"	8' 6"	11"	20.9"	16.1"	35.4"	4"	7"	2	10	40
B-SMART 10-150	150	10' 2"	8' 6"	11"	20.9"	16.1"	35.4"	4"	7"	2	15	53
B-SMART 10-200	200	10' 2"	8' 6"	11"	20.9"	16.1"	35.4"	4"	10"	2	20	53
B-SMART 12-200	200	12' 4"	10' 8"	11"	20.9"	16.1"	35.4"	4"	10"	2	20	53
B-SMART 14-200	200	14' 0"	12' 4"	11"	20.9"	16.1"	35.4"	4"	10"	2	20	53
B-SMART 10-250	250	10' 2"	8' 6"	11"	20.9"	16.1"	35.4"	4"	10"	2	25	79
B-SMART 12-250	250	12' 4"	10' 8"	11"	20.9"	16.1"	35.4"	4"	10"	2	25	79
B-SMART 14-250	250	14' 0"	12' 5"	11"	20.9"	16.1"	35.4"	4"	10"	2	25	79
B-SMART 20-250	250	20' 0"	16' 9"	11"	20.9"	16.1"	43.3"	6"	12"	4	25	79
B-SMART 10-350	350	10' 2"	8' 6"	15"	24.8"	16.1"	35.4"	6"	12"	2	40	106
B-SMART 12-350	350	12' 4"	10' 8"	15"	24.8"	16.1"	35.4"	6"	12"	2	40	106
B-SMART 14-350	350	14' 0"	12' 4"	15"	24.8"	16.1"	35.6"	6"	12"	2	50	79
B-SMART 20-350	350	20' 0"	16' 9"	15"	24.8"	16.1"	43.3"	6"	12"	4	40	106
B-SMART 12-440	440	13' 5"	11' 8"	15"	24.8"	20.1"	43.3"	6"	12"	2	40	106
B-SMART 14-440	440	14' 0"	12' 5"	15"	24.8"	20.1"	43.3"	6"	12"	2	40	106
B-SMART 20-440	500	20' 0"	16' 9"	15"	24.8"	20.1"	43.3"	6"	12"	4	50	119
B-SMART 14-550	500	14' 0"	12' 5"	15"	24.8"	20.1"	43.3"	6"	12"	2	50	119
B-SMART 20-550	550	20'	16' 9"	15"	24.8"	20.1"	47.2"	6"	12"	4	50	132

Due to ongoing product development, machine specifications can change at any time.

Extra daylight, stroke, increased throat depths readily available

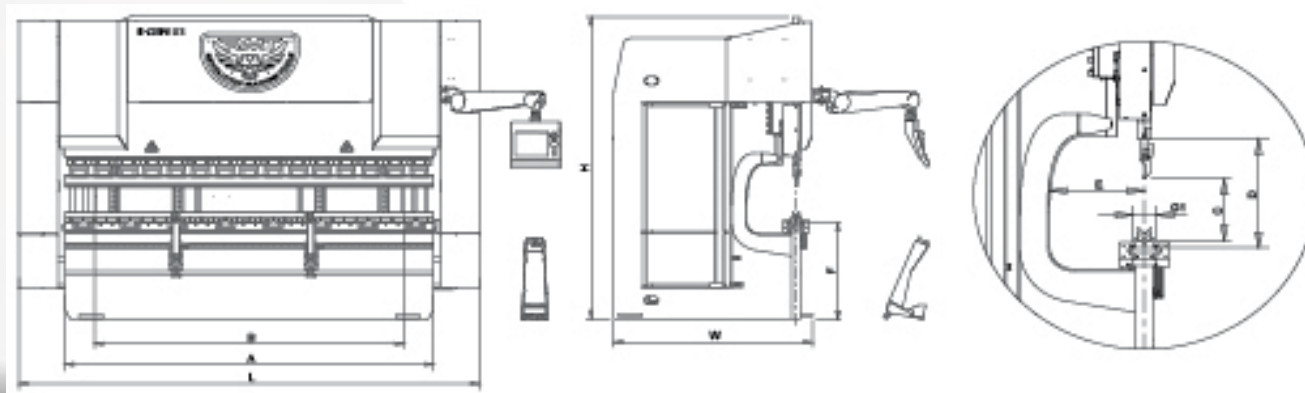



# B-SMART



B-SMART SERIES	RAM SPEEDS PROGRAMMABLE				BACK GAUGE SYSTEM						MACHINE DIMENSIONS			
	Y-AXIS APPROACH SPEED	Y-AXIS FORMING SPEED	DECOMPRESSION	Y-AXIS RETURN SPEED	X-AXIS SPEED	X-AXIS TRAVEL	3 <sup>RD</sup> GAUGEABLE FINGER POSITION	R-AXIS MAX SPEED	R-AXIS TRAVEL	# BACKGAUGE FINGER BLOCKS	LENGTH	WIDTH	HEIGHT	APPROX. WEIGHT
	Prog.	Prog.	Prog.	Prog.	Prog.	Prog.	Prog.	Std.	Std.	QTY	L	W	H	lbs
	I.P.M.	I.P.M.	I.P.M.	I.P.M.	I.P.M.	Inch	Inch	I.P.M.	Inch	Pcs.	Inch	Inch	Inch	lbs
B-SMART 6-70	94-472	0-24	0-24	94-472	5-1890	32.3"	41.7"	5-378	10.2"	2	128"	77"	108"	12,430
B-SMART 8-110	85-425	0-24	0-24	94-472	5-1890	32.3"	41.7"	5-378	10.2"	2	148"	77"	110"	15,070
B-SMART 10-110	85-425	0-24	0-24	94-472	5-1890	32.3"	41.7"	5-378	10.2"	2	167"	77"	110"	16,390
B-SMART 10-150	76-378	0-24	0-24	94-472	5-1890	32.3"	41.7"	5-378	10.2"	2	167"	85"	110"	19,030
B-SMART 10-200	66-331	0-21	0-21	85-425	5-1890	32.3"	41.7"	5-378	10.2"	2	167"	85"	110"	20,790
B-SMART 12-200	66-331	0-21	0-21	85-425	5-1890	32.3"	41.7"	5-378	10.2"	2	193"	85"	110"	24,090
B-SMART 14-200	66-331	0-21	0-21	85-425	5-1890	32.3"	41.7"	5-378	10.2"	2	208"	85"	112"	27,232
B-SMART 10-250	57-283	0-20	0-20	85-425	5-1890	32.3"	41.7"	5-378	10.2"	2	179"	89"	112"	25,300
B-SMART 12-250	57-283	0-20	0-20	85-425	5-1890	32.3"	41.7"	5-378	10.2"	2	201"	89"	114"	27,720
B-SMART 14-250	57-283	0-20	0-20	85-425	5-1890	32.3"	41.7"	5-378	10.2"	2	209"	89"	118"	32,120
B-SMART 20-250	47-236	0-20	0-20	85-425	5-1181	32.3"	41.7"	5-378	10.2"	4	295"	93"	126"	56,760
B-SMART 10-350	47-236	0-19	0-19	76-378	5-1890	32.3"	41.7"	5-378	10.2"	2	179"	97"	126"	36,960
B-SMART 12-350	47-236	0-19	0-19	76-378	5-1181	32.3"	41.7"	5-378	10.2"	2	201"	97"	124"	44,000
B-SMART 14-350	47-236	0-19	0-19	76-378	5-1181	32.3"	41.7"	5-378	10.2"	2	203"	81"	127"	50,089
B-SMART 20-350	43-213	0-19	0-19	76-378	5-1181	32.3"	41.7"	5-283	10.2"	4	295"	97"	132"	67,980
B-SMART 12-440	47-236	0-19	0-19	71-354	5-1181	40.2"	49.6"	5-283	10.2"	2	181"	85"	140"	55,116
B-SMART 14-440	47.236	0-19	0-19	71-354	5-1181	40.2"	49.6"	5-283	10.2"	2	221"	104"	137"	58,410
B-SMART 20-440	47-236	0-19	0-19	66-331	5-1181	40.2"	49.6"	5-283	10.2"	4	301"	104"	148"	87,340
B-SMART 14-550	43-213	0-18	0-18	66-331	5-1181	40.2"	49.6"	5-283	10.2"	2	211"	89"	146"	65,257
B-SMART 20-550	43-213	0-18	0-18	66-331	5-1181	40.2"	49.6"	5-283	10.2"	4	283"	89"	152"	89,067

Due to ongoing product development, machine specifications can change at any time.





# FORMING PRECISION PARTS WITH HIGH PRODUCTION?

## STANDARD 7 AXIS CNC SYNCRO PRESS BRAKE

Our design innovations are based on years of experience and have resulted in our B-GENIUS Press Brakes which allow for faster bending, and a better return and back gauge. RMT Press Brakes will allow you to mass produce precision parts effectively and decrease your cost per part.

## B-GENIUS SERIES



# B-GENIUS SERIES

## PRESS BRAKE

+ INDUSTRY 4.0



### STANDARD

- 7 Axis CNC:
  - Y1, Y2 precision ram positioning
  - X, R precision servo-driven back gauge
  - Z1, Z2 Axes
  - CNC motorized wave crowning
- Large trio of value:
  - Large open height
  - Large stroke
  - Large throat depth
- Safety laser with manual F. AKAS II M -FPSC-B-C + safety covers with switch
- Delem DA-66T touch screen CNC control unit with 3D graphical visualization
- Clamping:
  - American/European section-style box punch clamps (standard on 440 Ton and lower)
  - American-only style punch clamp available at no charge on 440 Ton and lower
- Standard X Axis travel is 32.3" with third gauge step capable of gauging parts up to 41.7" with standard back gauge (most machines)
- Stable and fast AC servo motor-driven precision back gauge with linear guide and ball bearing system (X, R, Z1, Z2)
- Quick-set sliding front sheet support arms with full-length linear guide, tilting stop and T-slot (front gauge squaring, etc.)
- Protection covers (side and rear safety doors)
- Rear work light
- World-class hydraulic and electronic components that are easily replaceable (parts stocked by RMT or available off-the-shelf from your local supplier):
  - Hydraulic blocks and valves (Hoerbiger)
  - Electronics system (Siemens, Schneider, Mitsubishi)
- Adjustable height suspension control unit arm
- High-yield plate construction
- Ability to accurately fade ram
- Stage bending
- Automatic bend sequence determination
- Automatic stretch length calculator for blank size determination
- Hydraulic Oil (up to 250 Ton machines)

### OPTIONAL

- Safety laser: Motorized F. AKAS III M
- Light curtain: SICK C 4000 for tandem/trio/quad machines
- Adaptive bending sensors (angle measurement)
- Up to 14+ Axes available:
  - X1, X2 Axes
  - R1, R2 Axes
  - X Prime (Delta X) Axis, +/- 5" stroke (10" total)
  - X Axis = 40" external travel – back protection with light barrier
- X1, X2 Axes for light pole production
- Sheet follower with sliding guide – motorized height adjustment
  - Front feeding system with supports
  - Front feeding system with supports – pneumatic pushers
- Other CNC control units available:
  - Delem DA-69T touch screen 2D/3D CNC control
  - Cybelec ModEva 10S/12S/15S 3D with PC 1200 3D SW
- Clamping:
  - Quick release clamping
  - RMT hydraulic or mechanical clamping
  - Wila or Wilson hydraulic or mechanical clamping
- Various tool options (RMT, Euro-American, Wila or Wilson)
- Extended back gauge stroke & back protection with light barrier
- Off-line software (V-Bend, Radbend, Profile-W)
- Tooling packages
- Multiple brake configurations available:
  - Tandem configuration
  - Trio configuration
  - Quad configuration
  - High tonnage flush floor models
- Custom colors
- Strain gauge's
- Material thickness measurement
- Keyed and interlocked frame



# B-GENIUS

B-GENIUS SERIES	STANDARD MACHINE CHARACTERISTICS											
	BENDING FORCE	BENDING LENGTH	DISTANCE BETWEEN FRAMES	LENGTH OF RAM STROKE	DAYLIGHT	THROAT DEPTH	BED HEIGHT	BED CAP WIDTH (STANDARD)	BED CAP WIDTH (OPTIONAL)	# SLIDING FRONT SUPPORT ARMS	MOTOR POWER	OIL TANK CAPACITY
	(US)	A	B	C	D	E	F	G1	G2	QTY		
	Tons	Feet	Feet	Inch	Inch	Inch	Inch	Inch	Inch	Pcs.	HP	Gal
B-GENIUS 6-70	70	6' 10"	5' 7"	11"	20.9"	16.1"	35.4"	4"	7"	2	10	40
B-GENIUS 8-110	110	8' 6"	7' 3"	11"	20.9"	16.1"	35.4"	4"	7"	2	15	53
B-GENIUS 10-110	110	10' 2"	8' 6"	11"	20.9"	16.1"	35.4"	4"	7"	2	15	53
B-GENIUS 10-150	150	10' 2"	8' 6"	11"	20.9"	16.1"	35.4"	4"	7"	2	20	79
B-GENIUS 10-200	200	10' 2"	8' 6"	11"	20.9"	16.1"	35.4"	4"	10"	2	20	79
B-GENIUS 12-200	200	12' 4"	10' 8"	11"	20.9"	16.1"	35.4"	4"	10"	2	20	79
B-GENIUS 14-200	200	14' 0"	12' 4"	11"	20.9"	16.1"	35.4"	4"	10"	2	30	79
B-GENIUS 10-250	250	10' 2"	8' 6"	11"	20.9"	16.1"	35.4"	4"	10"	2	25	79
B-GENIUS 12-250	250	12' 4"	10' 8"	11"	20.9"	16.1"	35.4"	4"	10"	2	25	79
B-GENIUS 14-250	250	14' 0"	12' 5"	11"	20.9"	16.1"	35.4"	4"	10"	2	25	79
B-GENIUS 20-250	250	20' 0"	16' 9"	11"	20.9"	16.1"	43.3"	6"	12"	4	25	79
B-GENIUS 10-350	350	10' 2"	8' 6"	15"	24.8"	16.1"	35.4"	6"	12"	2	40	106
B-GENIUS 12-350	350	12' 4"	10' 8"	15"	24.8"	16.1"	35.4"	6"	12"	2	40	106
B-GENIUS 14-350	350	14' 0"	12' 4"	15"	24.8"	16.1"	35.4"	6"	12"	2	40	106
B-GENIUS 20-350	350	20' 0"	16' 9"	15"	24.8"	16.1"	43.3"	6"	12"	4	40	106
B-GENIUS 12-440	440	13' 5"	11' 8"	15"	24.8"	20.1"	39.4"	6"	12"	2	40	106
B-GENIUS 14-440	440	14' 0"	12' 5"	15"	24.8"	20.1"	39.4"	6"	12"	2	40	106
B-GENIUS 20-440	440	20' 0"	16' 9"	15"	24.8"	20.1"	43.3"	6"	12"	4	40	106
B-GENIUS 14-550	500	14' 0"	12' 5"	15"	24.8"	20.1"	41.3"	6"	12"	2	60	119
B-GENIUS 20-550	550	20'	16' 9"	15"	24.8"	20.1"	35.4"	6"	12"	4	40	132

Due to ongoing product development, machine specifications can change at any time.

Extra daylight, stroke, increased throat depths readily available

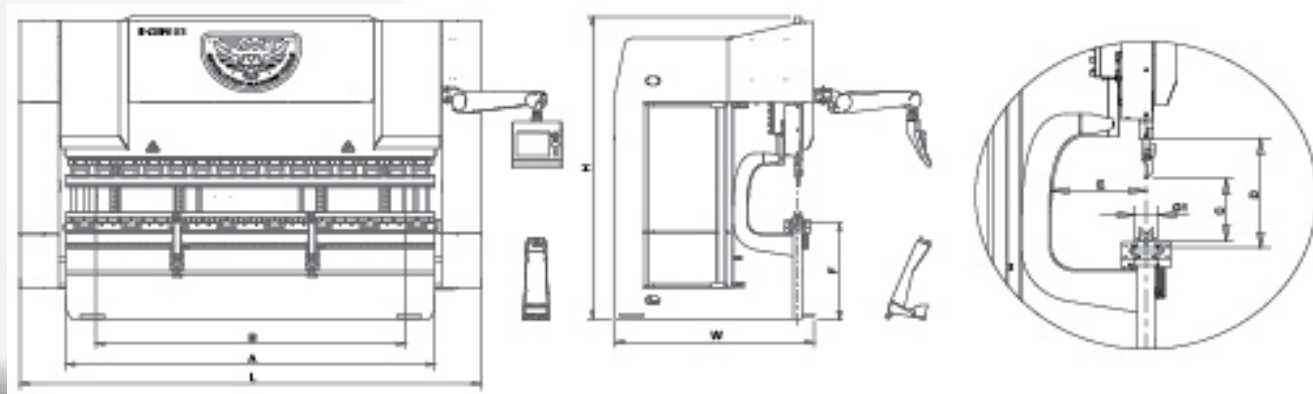

# B-GENIUS



B-GENIUS SERIES	RAM SPEEDS PROGRAMMABLE					BACK GAUGE SYSTEM							MACHINE DIMENSIONS			
	Y-AXIS APPROACH SPEED	Y-AXIS FORMING SPEED	Y-AXIS FORMING SPEED UP TO 350 TON	DECOMPRESSION	Y-AXIS RETURN SPEED	X-AXIS SPEED	X-AXIS TRAVEL	3 <sup>RD</sup> GAUGEABLE FINGER POSITION	R-AXIS MAX. SPEED	R-AXIS TRAVEL	Z1-Z2 AXIS MAX. SPEED	# BACKGAUGE FINGER BLOCKS	LENGTH	WIDTH	HEIGHT	APPROX. WEIGHT
	Prog.	Prog.	Opt.	Prog.	Prog.	Prog.	Prog.	Prog.	Std.	Std.	Opt.	QTY	L	W	H	lbs
	I.P.M.	I.P.M.	I.P.M.	I.P.M.	I.P.M.	I.P.M.	Inch	Inch	I.P.M.	Inch	I.P.M.	Pcs.	Inch	Inch	Inch	lbs
B-GENIUS 6-70	94-472	0-24	0-50	0-24	94-472	5-1890	32.3"	41.7"	5-378	10.2"	5-3425	2	128"	77"	108"	12,790
B-GENIUS 8-110	94-472	0-24	0-50	0-24	94-472	5-1890	32.3"	41.7"	5-378	10.2"	5-3425	2	148"	77"	110"	15,400
B-GENIUS 10-110	94-472	0-24	0-50	0-24	94-472	5-1890	32.3"	41.7"	5-378	10.2"	5-3425	2	167"	77"	110"	16,720
B-GENIUS 10-150	94-472	0-24	0-50	0-24	94-472	5-1890	32.3"	41.7"	5-378	10.2"	5-3425	2	167"	80"	110"	19,360
B-GENIUS 10-200	85-425	0-24	0-50	0-24	85-425	5-1890	32.3"	41.7"	5-378	10.2"	5-3425	2	167"	84"	110"	21,120
B-GENIUS 12-200	85-425	0-24	0-50	0-24	85-425	5-1890	32.3"	41.7"	5-378	10.2"	5-3425	2	193"	85"	110"	24,420
B-GENIUS 14-200	85-425	0-24	0-50	0-24	85-425	5-1890	32.3"	41.7"	5-378	10.2"	5-3425	2	201"	67"	115"	31,306
B-GENIUS 10-250	76-378	0-24	0-50	0-24	85-425	5-1890	32.3"	41.7"	5-378	10.2"	5-3425	2	179"	89"	112"	25,740
B-GENIUS 12-250	76-378	0-24	0-50	0-24	85-425	5-1890	32.3"	41.7"	5-378	10.2"	5-3425	2	201"	87"	114"	28,160
B-GENIUS 14-250	76-378	0-24	0-50	0-24	85-425	5-1890	32.3"	41.7"	5-378	10.2"	5-3425	2	209"	89"	118"	32,560
B-GENIUS 20-250	66-331	0-24	0-50	0-24	85-425	5-1181	32.3"	41.7"	5-378	10.2"	5-3445	4	295"	93"	126"	57,200
B-GENIUS 10-350	66-331	0-24	0-50	0-24	76-378	5-1890	32.3"	41.7"	5-378	10.2"	5-3425	2	179"	97"	126"	38,500
B-GENIUS 12-350	66-331	0-24	0-50	0-24	76-378	5-1890	32.3"	41.7"	5-378	10.2"	5-3425	2	201"	97"	124"	45,760
B-GENIUS 14-350	66-331	0-24	0-50	0-24	76-378	5-1890	32.3"	41.7"	5-378	10.2"	5-3425	2	211"	97"	124"	48,400
B-GENIUS 20-350	57-283	0-24	0-50	0-24	76-378	5-1181	32.3"	41.7"	5-283	10.2"	5-3445	4	295"	97"	132"	70,400
B-GENIUS 12-440	57-283	0-21	0-50	0-21	71-354	5-1181	40.2"	49.6"	5-283	10.2"	5-3425	2	215"	104"	137"	59,400
B-GENIUS 14-440	57-283	0-21	0-50	0-21	66-331	5-1181	40.2"	49.6"	5-283	10.2"	5-3425	2	220"	104"	136"	60,060
B-GENIUS 20-440	57-283	0-21	0-50	0-21	66-331	5-1181	40.2"	49.6"	5-283	10.2"	5-3445	4	301"	104"	148"	89,320
B-GENIUS 14-550	52-260	0-21	0-50	0-21	66-331	5-1181	40.2"	49.6"	5-283	10.2"	5-3425	2	211"	89"	146"	66,139
B-GENIUS 20-550	47-236	0-21	0-50	0-21	66-331	5-1181	40.2"	49.6"	5-283	10.2"	5-3445	4	311"	104"	146"	96,800

Due to ongoing product development, machine specifications can change at any time.





# NEED QUICKER PRODUCTION?

Thanks to its quiet operation and low energy consumption, the B-GENIUS-E press brake has about 69% less energy consumption than hydraulic press brakes.

No hydraulic oil is required for the operation of the machine. Maintenance costs are minimal since there are not any hydraulic system components, such as filters, sealings, etc. No issues with work area contamination, due to no oil leakage.

- 98% energy saving in standby
- Quick and easy tool replacement
- Precise bending
- Short-term depreciation
- User friendly touch screen
- Electro-mechanical press brake

## B-GENIUS-E SERIES



# B-GENIUS-E

## PRESS BRAKE

+ INDUSTRY 4.0



### STANDARD

- 6 Axis CNC:
  - Y1, Y2 precision ram positioning
  - X, R precision servo-driven back gauge
  - Z1, Z2 Axes
- Large trio of value:
  - Large open height
  - Large stroke
  - Large throat depth
- Safety laser with manual F. AKAS II M -FPSC-B-C + safety covers with switch
- Delem DA-66T touch screen CNC control unit with 3D graphical visualization
- Clamping:
  - American/European section-style box punch clamps
  - American-only style punch clamp available
- Standard X Axis travel is 32.3" with third gauge step capable of gauging parts up to 41.7" with standard back gauge (most machines)
- Stable and fast AC servo motor-driven precision back gauge with linear guide and ball bearing system (X, R, Z1, Z2)
- Quick-set sliding front sheet support arms with full-length linear guide, tilting stop and T-slot (front gauge squaring, etc.)
- Protection covers (side and rear safety doors)
- Rear work light
- World-class electronic components that are easily replaceable (parts stocked by RMT or available off-the-shelf from your local supplier):
  - Electronics system (Siemens, Schneider, Mitsubishi)
- Adjustable height suspension control unit arm
- High-yield plate construction
- Ability to accurately fade ram
- Stage bending
- Automatic bend sequence determination
- Automatic stretch length calculator for blank size determination

### OPTIONAL

- Safety laser: Motorized F. AKAS III M
- Light curtain: SICK C 4000 for tandem/trio/quad machines
- Adaptive bending sensors (angle measurement)
- Up to 14+ Axes available:
  - X1, X2 Axes
  - R1, R2 Axes
  - X Prime (Delta X) Axis, +/- 5" stroke (10" total)
  - X Axis = 40" external travel – back protection with light barrier
  - X1, X2 Axes for light pole production
  - Sheet follower with sliding guide – motorized height adjustment
  - Front feeding system with supports
  - Front feeding system with supports – pneumatic pushers
- Other CNC control units available:
  - Delem DA-69T touch screen 2D/3D CNC control
  - Cybelec ModEva 10S/12S/15S 3D with PC 1200 3D SW
- Clamping:
  - Quick release clamping
  - RMT hydraulic or mechanical clamping
  - Wila or Wilson hydraulic or mechanical clamping
- Various tool options (RMT, Euro-American, Wila or Wilson)
- Extended back gauge stroke & back protection with light barrier
- Off-line software (V-Bend, Radbend, Profile-W)
- Tooling packages
- Custom Colors



# B-GENIUS-E

B-GENIUS-E SERIES	STANDARD MACHINE CHARACTERISTICS								
	BENDING FORCE	BENDING LENGTH	DISTANCE BETWEEN FRAMES	LENGTH OF RAM STROKE	DAYLIGHT	BED HEIGHT	BED CAP WIDTH (STANDARD)	# SLIDING FRONT SUPPORT ARMS	MAIN SERVO MOTOR POWER
	(US)	A	B	C	D	F	G1	QTY	
	Tons	Feet	Feet	Inch	Inch	Inch	Inch	Pcs.	HP
B-GENIUS-E 5-44	44	5'3"	73.2"	12"	23.2"	41.3"	2.4"	2	7.37
B-GENIUS-E 6-72	72	6'11"	92.9"	12"	23.2"	41.3"	2.4"	2	7.37
B-GENIUS-E 8-88	88	8'6"	112.6"	12"	23.2"	41.3"	2.4"	2	7.37
B-GENIUS-E 10-110	110	10'2"	132.3"	12"	23.2"	41.3"	2.4"	2	7.37

Due to ongoing product development, machine specifications can change at any time.





# B-GENIUS-E



B-GENIUS-E SERIES	RAM SPEEDS PROGRAMMABLE					BACK GAUGE SYSTEM						MACHINE DIMENSIONS			
	Y-AXIS APPROACH SPEED	Y-AXIS FORMING SPEED	Y-AXIS FORMING SPEED UP TO 350 TON	DECOMPRESSION	Y-AXIS RETURN SPEED	X-AXIS SPEED	X-AXIS TRAVEL	R-AXIS MAX SPEED	R-AXIS TRAVEL	Z1-Z2 AXIS MAX. SPEED	# BACKGAUGE FINGER BLOCKS	LENGTH	WIDTH	HEIGHT	APPROX. WEIGHT
	Prog.	Prog.	Opt.	Prog.	Prog.	Prog.	Prog.	Std.	Std.	Opt.	QTY	L	W	H	lbs
	I.P.M.	I.P.M.	I.P.M.	I.P.M.	I.P.M.	I.P.M.	Inch	I.P.M.	Inch	I.P.M.	Pcs.	Inch	Inch	Inch	lbs
B-GENIUS-E 5-44	94-426	0-24	0-50	0-24	94-426	5-1182	31.5"	5-588	9.8"	5-2364	2	132.7"	90.2"	113.8"	10,694
B-GENIUS-E 6-72	94-282	0-24	0-50	0-24	94-282	5-1182	31.5"	5-588	9.8"	5-2364	2	152.4"	90.2"	113.8"	12,458
B-GENIUS-E 8-88	94-210	0-24	0-50	0-24	94-210	5-1182	31.5"	5-588	9.8"	5-2364	2	172"	90.2"	113.8"	14,333
B-GENIUS-E 10-110	94-180	0-24	0-50	0-24	94-180	5-1182	31.5"	5-588	9.8"	5-2364	2	191.7"	90.2"	113.8"	16,538

Due to ongoing product development, machine specifications can change at any time.



Maximize your safety with the rear sliding cover and switch. Check inside the machine by means of the windows



# NEED MORE EFFICIENCY?

B-GENIUS-H is our hybrid press brake which provides accurate bends even for small parts at different points thanks to high repeatability and bending precision.

- Fast operating press brake using servo motors and highly efficient pump.
- Most accurate, having high bending accuracy between  $\pm .00003''$
- Very Eco-friendly, saving 65% energy in comparison to standard press brakes. It also uses 95% less oil, which helps reduce manufacturing costs.
- Highest bending efficiency is achieved and no pressure is lost through proportional valves.
- Quietest press brake, at a noise level of 63db. (TUV-SUD certified)
- Fewer oil changes required, at 7000 working hours
- No oil heat up thanks to the pumping system which does not run when the machine is in stand-by mode.
- Provides flawless bending for small parts at different points.
- Ease of maintenance. Y1 and Y2 axes have stand-alone oil tanks. Very low maintenance required.

## B-GENIUS-H SERIES



# B-GENIUS-H

## PRESS BRAKE

+ INDUSTRY 4.0



### STANDARD

- 7 Axis CNC:
  - Y1, Y2 precision ram positioning
  - X, R precision servo-driven back gauge
  - Z1, Z2 Axes
- Back CNC crowning
- Large trio of value:
  - Large open height
  - Large stroke
  - Large throat depth
- Safety laser with manual F. AKAS II M -FPSC-B-C + safety covers with switch
- Delem DA-66T touch screen CNC control unit with 3D graphical visualization
- Clamping:
  - American/European section-style box punch clamps
  - American-only style punch clamp available
- Standard X Axis travel is 32.3" with third gauge step capable of gauging parts up to 41.7" with standard back gauge (most machines)
- Stable and fast AC servo motor-driven precision back gauge with linear guide and ball bearing system (X, R, Z1, Z2)
- Quick-set sliding front sheet support arms with full-length linear guide, tilting stop and T-slot (front gauge squaring, etc.)
- Protection covers (side and rear safety doors)
- Rear work light
- World-class electronic components that are easily replaceable (parts stocked by RMT or available off-the-shelf from your local supplier):
  - Electronics system (Siemens, Schneider, Mitsubishi)
- Adjustable height suspension control unit arm
- High-yield plate construction
- Ability to accurately fade ram
- Stage bending
- Automatic bend sequence determination
- Automatic stretch length calculator for blank size determination

### OPTIONAL

- Safety laser: Motorized F. AKAS III M
- Light curtain: SICK C 4000 for tandem/trio/quad machines
- Adaptive bending sensors (angle measurement)
- Up to 14+ Axes available:
  - X1, X2 Axes
  - R1, R2 Axes
  - X Prime (Delta X) Axis, +/- 5" stroke (10" total)
  - X Axis = 40" external travel – back protection with light barrier
  - X1, X2 Axes for light pole production
  - Sheet follower with sliding guide – motorized height adjustment
  - Front feeding system with supports
  - Front feeding system with supports – pneumatic pushers
- Other CNC control units available:
  - Delem DA-69T touch screen 2D/3D CNC control
  - Cybelec ModEva 10S/12S/15S 3D with PC 1200 3D SW
- Clamping:
  - Quick release clamping
  - RMT hydraulic or mechanical clamping
  - Wila or Wilson hydraulic or mechanical clamping
- Various tool options (RMT, Euro-American, Wila or Wilson)
- Extended back gauge stroke & back protection with light barrier
- Off-line software (V-Bend, Radbend, Profile-W)
- Tooling packages
- Multiple brake configurations available:
  - Tandem configuration
  - Trio configuration
  - Quad configuration
  - High tonnage flush floor models
- Custom Colors



# B-GENIUS-H

B-GENIUS-H SERIES	STANDARD MACHINE CHARACTERISTICS										
	BENDING FORCE	BENDING LENGTH	DISTANCE BETWEEN FRAMES	LENGTH OF RAM STROKE	DAYLIGHT	THROAT DEPTH	BED HEIGHT	BED CAP WIDTH (STANDARD)	BED CAP WIDTH (OPTIONAL)	# SLIDING FRONT SUPPORT ARMS	OIL TANK CAPACITY
	(US)	A	B	C	D	E	F	G1	G2	QTY	
	Tons	Feet	Feet	Inch	Inch	Inch	Inch	Inch	Inch	Pcs.	Gal
B-GENIUS-H 8-110	110	8' 6"	7' 3"	11"	20.9"	16.1"	35.4"	4"	7"	2	9
B-GENIUS-H 10-110	110	10' 2"	8' 4"	11"	20.9"	16.1"	35.4"	4"	7"	2	9
B-GENIUS-H 8-150	150	8' 6"	7' 3"	11"	21.7"	16.1"	35.4"	4"	7"	2	9
B-GENIUS-H 10-150	150	10' 2"	8' 4"	11"	21.7"	16.1"	35.4"	4"	7"	2	9
B-GENIUS-H 12-150	150	12' 4"	10' 8"	11"	21.7"	16.1"	35.4"	4"	7"	2	9
B-GENIUS-H 13-150	150	13' 5"	11' 10"	11"	21.7"	16.1"	35.4"	4"	7"	2	9
B-GENIUS-H 14-150	150	14'	12' 5"	11"	21.7"	16.1"	35.4"	4"	7"	2	9
B-GENIUS-H 10-200	200	10' 2"	8' 4"	11"	21.7"	16.1"	35.4"	4"	10"	2	9
B-GENIUS-H 12-200	200	12' 4"	10' 8"	11"	21.7"	16.1"	35.4"	4"	10"	2	15
B-GENIUS-H 13-200	200	13' 5"	11' 10"	11"	21.7"	16.1"	35.4"	4"	10"	2	15
B-GENIUS-H 14-200	200	14'	12' 5"	11"	21.7"	16.1"	35.4"	4"	10"	2	15
B-GENIUS-H 10-250	250	10' 2"	8' 4"	11"	21.7"	16.1"	35.4"	8"	10"	2	15
B-GENIUS-H 12-250	250	12' 4"	10' 8"	11"	21.7"	16.1"	35.4"	6"	10"	2	15
B-GENIUS-H 13-250	250	13' 5"	11' 10"	11"	21.7"	16.1"	35.4"	6"	10"	2	15
B-GENIUS-H 14-250	250	14'	12' 5"	11"	21.7"	16.1"	35.4"	6"	10"	2	15
B-GENIUS-H 10-300	300	10' 2"	8' 4"	11"	21.7"	16.1"	35.4"	6"	10"	2	15
B-GENIUS-H 12-300	300	12' 4"	10' 8"	11"	21.7"	16.1"	35.4"	6"	10"	2	15
B-GENIUS-H 13-300	300	13' 5"	11' 10"	11"	21.7"	16.1"	35.4"	8"	10"	2	15
B-GENIUS-H 14-300	300	14'	12' 5"	11"	21.7"	16.1"	35.4"	8"	10"	2	15

Due to ongoing product development, machine specifications can change at any time.



# B-GENIUS-H



B-GENIUS-H SERIES	RAM SPEEDS PROGRAMMABLE					BACK GAUGE SYSTEM							MACHINE DIMENSIONS			
	Y-AXIS APPROACH SPEED	Y-AXIS FORMING SPEED	Y-AXIS FORMING SPEED UP TO 350 TON	DECOMPRESSION	Y-AXIS RETURN SPEED	X-AXIS SPEED	X-AXIS TRAVEL	3 <sup>RD</sup> GAUGEABLE FINGER POSITION	R-AXIS MAX SPEED	R-AXIS TRAVEL	Z1-Z2 AXIS MAX. SPEED	# BACKGAUGE FINGER BLOCKS	LENGTH	WIDTH	HEIGHT	APPROX. WEIGHT
	Prog.	Prog.	Opt.	Prog.	Prog.	Prog.	Prog.	Prog.	Std.	Std.	Opt.	QTY	L	W	H	lbs
	I.P.M.	I.P.M.	I.P.M.	I.P.M.	I.P.M.	I.P.M.	Inch	Inch	I.P.M.	Inch	I.P.M.	Pcs.	Inch	Inch	Inch	lbs
B-GENIUS-H 8-110	94-472	0-24	0-50	0-24	94-472	5-1181	31.5"	41.7"	5-828	9.8"	5-3425	2	181"	87"	106"	13,451
B-GENIUS-H 10-110	94-472	0-24	0-50	0-24	94-472	5-1181	31.5"	41.7"	5-828	9.8"	5-3425	2	201"	87"	106"	14,553
B-GENIUS-H 8-150	76-378	0-28	0-50	0-24	90-450	5-1181	31.5"	41.7"	5-828	9.8"	5-3425	2	181"	87"	106"	16,538
B-GENIUS-H 10-150	94-472	0-28	0-50	0-24	90-450	5-1181	31.5"	41.7"	5-828	9.8"	5-3425	2	201"	87"	106"	17,940
B-GENIUS-H 12-150	94-472	0-28	0-50	0-24	90-450	5-1181	31.5"	41.7"	5-828	9.8"	5-3425	2	227"	87"	106"	20,617
B-GENIUS-H 13-150	94-472	0-28	0-50	0-24	90-450	5-1181	31.5"	41.7"	5-828	9.8"	5-3425	2	240"	87"	106"	23,814
B-GENIUS-H 14-150	94-472	0-28	0-50	0-24	90-450	5-1181	31.5"	41.7"	5-828	9.8"	5-3425	2	247"	87"	106"	24,255
B-GENIUS-H 10-200	85-425	0-28	0-50	0-24	90-450	5-1181	31.5"	41.7"	5-828	9.8"	5-3425	2	201"	87"	106"	19,404
B-GENIUS-H 12-200	85-425	0-28	0-50	0-24	90-450	5-1181	31.5"	41.7"	5-828	9.8"	5-3425	2	227"	87"	106"	22,381
B-GENIUS-H 13-200	85-425	0-28	0-50	0-24	90-450	5-1181	31.5"	41.7"	5-828	9.8"	5-3425	2	240"	87"	106"	25,358
B-GENIUS-H 14-200	85-425	0-28	0-50	0-24	90-450	5-1181	31.5"	41.7"	5-828	9.8"	5-3425	2	247"	87"	106"	25,799
B-GENIUS-H 10-250	85-425	0-24	0-50	0-24	94-472	5-1181	31.5"	41.7"	5-828	9.8"	5-3425	2	201"	89"	106"	24,476
B-GENIUS-H 12-250	85-425	0-24	0-50	0-24	94-472	5-1181	31.5"	41.7"	5-828	9.8"	5-3425	2	227"	89"	107"	28,004
B-GENIUS-H 13-250	85-425	0-24	0-50	0-24	94-472	5-1181	31.5"	41.7"	5-828	9.8"	5-3425	2	240"	89"	110"	29,216
B-GENIUS-H 14-250	85-425	0-24	0-50	0-24	94-472	5-1181	31.5"	41.7"	5-828	9.8"	5-3425	2	247"	89"	110"	29,768
B-GENIUS-H 10-300	66-331	0-26	0-50	0-24	66-331	5-1181	31.5"	41.7"	5-828	9.8"	5-3425	2	201"	90"	121"	29,768
B-GENIUS-H 12-300	85-425	0-24	0-50	0-24	94-472	5-1181	31.5"	41.7"	5-828	9.8"	5-3425	2	227"	90"	121"	35,280
B-GENIUS-H 13-300	66-331	0-26	0-50	0-24	66-331	5-1181	31.5"	41.7"	5-828	9.8"	5-3425	2	240"	90"	122"	37,044
B-GENIUS-H 14-300	66-331	0-26	0-50	0-24	66-331	5-1181	31.5"	41.7"	5-828	9.8"	5-3425	2	247"	90"	122"	37,706

Due to ongoing product development, machine specifications can change at any time.





# FORMING THICK, LONG, HIGH TENSILE METAL?

## 7 AXIS CNC PRESS BRAKE

RMT can customize a total bending solution for your application that includes high tonnage press brakes, as well as material handing equipment to create a turnkey automatic bending solution. The B-GIANT may be the perfect machine for your process.

Benefits of a B-GIANT solution include:

- Flexibility of bending for diversified uses
- Accuracy for large and high spring-back sheets
- Faster set-up times with automatic loading and unloading of materials
- Improved safety for employees

Using advanced technologies for bending large sheet metal can, in some applications, reduce the need for long, expensive welding operations. This not only saves money, it reduces negative impact on material stability that can occur during welding.

## B-GIANT SERIES



# B-GIANT SERIES

## PRESS BRAKE

+ INDUSTRY 4.0



### STANDARD

- 7 Axis CNC:
  - Y1, Y2 precision ram positioning
  - X, R precision servo-driven back gauge
  - Z1, Z2 Axes
  - CNC motorized wave crowning
- Large trio of value:
  - Large open height
  - Large stroke
  - Large throat depth
- Safety laser with manual F. AKAS II M -FPSC-B-C + safety covers with switch
- Delem DA-66T touch screen CNC control unit with 3D graphical visualization
- Clamping:
  - American/European section-style box punch clamps  
(standard on 440 Ton and lower)
    - American-only style punch clamp available at no charge on 440 Ton and lower
  - Standard X Axis travel is 32.3" with third gauge step capable of gauging parts up to 41.7" with standard back gauge (most machines)
  - Stable and fast AC servo motor-driven precision back gauge with linear guide and ball bearing system (X, R, Z1, Z2)
  - Quick-set sliding front sheet support arms with full-length linear guide, tilting stop and T-slot (front gauge squaring, etc.)
  - Protection covers (side and rear safety doors)
  - Rear work light
  - World-class hydraulic and electronic components that are easily replaceable (parts stocked by RMT or available off-the-shelf from your local supplier):
    - Hydraulic blocks and valves (Hoerbiger)
    - Electronics system (Siemens, Schneider, Mitsubishi)
  - Adjustable height suspension control unit arm
  - High-yield plate construction
  - Ability to accurately fade ram
  - Stage bending
  - Automatic bend sequence determination
  - Automatic stretch length calculator for blank size determination

### OPTIONAL

- Safety laser: Motorized F. AKAS III M
- Light curtain: SICK C 4000 for tandem/trio/quad machines
- Adaptive bending sensors (angle measurement)
- Up to 14+ Axes available:
  - X1, X2 Axes
  - R1, R2 Axes
  - X Prime (Delta X) Axis, +/- 5" stroke (10" total)
  - X Axis = 40" external travel – back protection with light barrier
    - X1, X2 Axes for light pole production
    - Sheet follower with sliding guide – motorized height adjustment
      - Front feeding system with supports
      - Front feeding system with supports – pneumatic pushers
- Other CNC control units available:
  - Delem DA-69T touch screen 2D/3D CNC control
  - Cybelec ModEva 10S/12S/15S 3D with PC 1200 3D SW
- Clamping:
  - Quick release clamping
  - RMT hydraulic or mechanical clamping
  - Wila or Wilson hydraulic or mechanical clamping
- Various tool options (RMT, Euro-American, Wila or Wilson)
- Extended back gauge stroke & back protection with light barrier
- Off-line software (V-Bend, Radbend, Profile-W)
- Tooling packages
- Multiple brake configurations available:
  - Tandem configuration
  - Trio configuration
  - Quad configuration
  - High tonnage flush floor models
- Custom Colors



# B-GIANT

B-GIANT SERIES	STANDARD MACHINE CHARACTERISTICS													
	BENDING FORCE	BENDING LENGTH	DISTANCE BETWEEN FRAMES	LENGTH OF RAM STROKE	DAYLIGHT	THROAT DEPTH	BED HEIGHT	BED CAP WIDTH (STANDARD)	BED CAP WIDTH (OPTIONAL)	# SLIDING FRONT SUPPORT ARMS	MOTOR POWER	OIL TANK CAPACITY	DEPTH OF PIT	
	(US)	A	B	C	D	E	F	G1	G2	QTY			P1	P2
	Tons	Feet	Feet	Inch	Inch	Inch	Inch	Inch	Inch	Pcs.	HP	Gal	Inch	Inch
B-GIANT 14-660	660	14' 1"	12' 4"	15.2"	24.4"	20.1"	47.2"	12'	19.7"	2	60	132	-	-
B-GIANT 20-660	660	20'	16' 8"	15.2"	24.4"	20.1"	41.3"	12'	19.7"	4	60	132	14.6"	45.3"
B-GIANT 20-900	900	20'	16' 8"	19.7"	29.5"	29.5"	41.3"	12'	19.7"	4	60	185	23.6"	47.2"
B-GIANT 23-900	900	23' 3"	16' 8"	19.7"	29.5"	29.5"	41.3"	12'	19.7"	4	60	185	23.6"	47.2"
B-GIANT 26-900	900	26' 6"	19' 10"	19.7"	29.5"	29.5"	41.3"	12'	19.7"	4	60	185	27.6"	66.9"
B-GIANT 20-1100	1100	20'	16' 8"	19.7"	29.5"	29.5"	31.5"	19.7"	RQST	4	75	238	27.6"	59.1"
B-GIANT 23-1100	1100	23' 3"	16' 8"	19.7"	29.5"	29.5"	31.5"	19.7"	RQST	4	75	238	27.6"	59.1"
B-GIANT 26-1100	1100	26' 6"	19' 10"	19.7"	29.5"	29.5"	31.5"	19.7"	RQST	4	75	238	27.6"	74.8"
B-GIANT 23-1400	1400	23' 3"	16' 8"	19.7"	29.5"	29.5"	31.5"	19.7"	RQST	4	100	264	27.6"	74.8"
B-GIANT 26-1400	1400	26' 6"	19' 10"	19.7"	29.5"	29.5"	31.5"	19.7"	RQST	4	100	264	27.6"	56.6"
B-GIANT 26-1800	1800	26' 6"	20'	23.6"	33.5"	29.5"	39.4"	19.7"	RQST	4	120	330	39.4"	63.0"
B-GIANT 26-2200	2200	26' 6"	20'	23.6"	33.5"	29.5"	41.3"	19.7"	RQST	4	180	396	39.4"	78.7"
	2200+	26+	PLEASE CONSULT YOUR DEALER OR RMT REPRESENTATIVE											

Due to ongoing product development, machine specifications can change at any time.





# B-GIANT



B-GIANT SERIES	RAM SPEEDS PROGRAMMABLE				BACK GAUGE SYSTEM						MACHINE DIMENSIONS		
	Y-AXIS APPROACH SPEED	Y-AXIS FORMING SPEED	DECOMPRESSION	Y-AXIS RETURN SPEED	X-AXIS SPEED	X-AXIS TRAVEL	3 <sup>RD</sup> GAUGEABLE FINGER POSITION	CNC R-AXIS MAX SPEED	CNC R-AXIS TRAVEL	# BACKGAUGE FINGER BLOCKS	LENGTH	WIDTH	HEIGHT
	Prog.	Prog.	Prog.	Prog.	Prog.	Prog.	Prog.	Std.	Std.	QTY	L	W	H
	I.P.M.	I.P.M.	I.P.M.	I.P.M.	I.P.M.	Inch	Inch	I.P.M.	Inch	Pcs.	Inch	Inch	Inch
B-GIANT 14-660	0-213	0-19	0-24	20-165	1-709	39"	49"	1-189	10"	2	213"	94"	157"
B-GIANT 20-660	0-213	0-19	0-24	20-166	1-709	39"	49"	1-189	10"	4	283"	94"	163"
B-GIANT 20-900	0-165	0-14	0-24	18-142	1-709	39"	49"	1-189	10"	4	283"	110"	187"
B-GIANT 23-900	0-165	0-14	0-24	18-142	1-709	39"	49"	1-189	10"	4	323"	110"	187"
B-GIANT 26-900	0-165	0-14	0-24	18-142	1-709	39"	49"	1-189	10"	4	362"	110"	197"
B-GIANT 20-1100	0-165	0-14	0-24	18-142	1-709	49"	59"	1-189	10"	4	283"	114"	193"
B-GIANT 23-1100	0-165	0-14	0-24	18-142	1-709	49"	59"	1-189	10"	4	323"	114"	193"
B-GIANT 26-1100	0-165	0-14	0-24	18-142	1-709	49"	59"	1-189	10"	4	362"	118"	197"
B-GIANT 23-1400	0-165	0-14	0-24	18-142	1-709	49"	59"	1-189	10"	4	323"	126"	197"
B-GIANT 26-1400	0-165	0-12	0-24	18-142	1-709	49"	59"	1-189	10"	4	362"	126"	205"
B-GIANT 26-1800	0-165	0-12	0-24	18-142	1-709	59"	79"	1-59	15.7"	4	362"	132"	220"
B-GIANT 26-2200	0-165	0-12	0-24	18-142	1-709	59"	69"	1-59	15.7"	4	362"	146"	228"

Due to ongoing product development, machine specifications can change at any time.





*Hydraulic Presses*

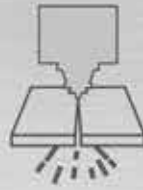

*Fiber Lasers*



*PSM Pipe Lathe*

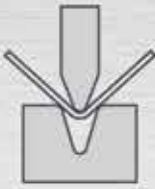

*Press Brakes*

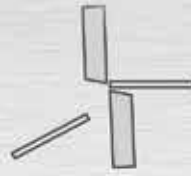

*Shears*

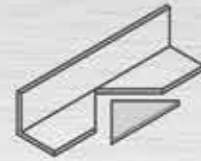

*Ironworkers*

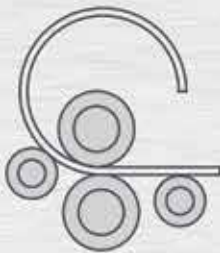

*Plate Rolls*

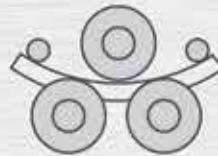

*Angle Rolls*

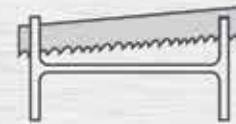

*Bandsaws*

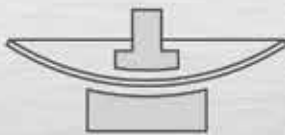

*Dishing Presses*

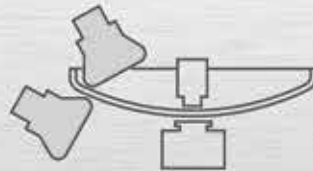

*Flanging Machines*



*Drilling Machines*

*"If you need a machine and don't buy it, you'll find that you have paid for it anyway, but don't have it."*

*Henry Ford*

Revolution Machine Tools  
385 N 700 W  
North Salt Lake, UT 84054

[www.RMTUS.com](http://www.RMTUS.com)  
info@rmtus.com

Phone: 844.RMT.INFO  
844.768.4636

**KYSON**